

KAISAI

HEAT PUMP R290

MONO TYPE

KHOA-06PMA1

KHOA-08PMA1

KHOA-10PMA1

Owner's Manual

Thank you for choosing our product. For proper operation, please read and keep this manual carefully.

If you have lost the Owner's Manual, please contact the local agent or visit www.kaisai.com or sent email to: handlowy@kaisai.com, for electronic version.

CONTENTS

1 SAFETY PRECAUTIONS	60
2 GENERAL INTRODUCTION	68
2.1 Documentation	68
2.2 Validity of the instructions	68
2.3 Unpacking	69
2.4 Accessories of the unit	69
2.5 Transportation	70
2.6 Parts to be removed	71
2.7 Operation range	72
2.8 Hydraulic module	73
3 SAFETY ZONE	74
4 UNIT INSTALLATION	75
4.1 Conditions for installation	76
4.2 Foundation and unit installation (installation on a ground)	76
4.3 Drainage	76
4.4 In cold climates	77
5 HYDRAULIC INSTALLATION	78
5.1 Preparations for installation	78
5.2 Water loop connection	78
5.3 Filling water loop with water	79
5.4 Filling domestic hot water tank with water	79
5.5 Water pipe insulation	79
5.6 Freeze protection	79
5.7 Water	81
6 ELECTRICAL INSTALLATION	82
6.1 Opening the electrical box cover	82
6.2 Back plate layout for wiring	82
6.3 Electrical wiring	82
6.4 Connection of power supply	83
6.5 Connection of other components	84
6.6 Cascade function	90
6.7 Connection of other optional components	90
7 INSTALLATION OF WIRED CONTROLLER	91
7.1 Materials for installation	91
7.2 Dimensions	91
7.3 Wiring	91
7.4 Mounting	92

- 8 COMPLETION OF INSTALLATION.....94**

- 9 CONFIGURATION95**
 - 9.1 Checks before configuration.....95
 - 9.2 Configuration96
 - 9.3 Modbus mapping table96

- 10 COMMISSIONING.....97**
 - 10.1 Test run for the actuator97
 - 10.2 Air purge97
 - 10.3 Test run.....98
 - 10.4 Check of the minimum flow rate98

- 11 HAND-OVER TO THE USER.....98**

- 12 MAINTENANCE99**
 - 12.1 Safety precautions for maintenance99
 - 12.2 Maintenance checklist99

- 13 TECHNICAL DATA100**
 - 13.1 General.....100
 - 13.2 Piping diagram.....101
 - 13.3 Wiring diagram103

- ANNEX.....104**
 - Annex A. Menu structure (wired controller)104
 - Annex B. Operation settings.....106
 - Annex C. Terms and abbreviation109

1 SAFETY PRECAUTIONS

Observe the basic safety regulations before starting work and operation.

Meaning of hazard severity panels

DANGER

Indicates a hazard with a high level of risk which, if not avoided, will result in death or serious injury.

WARNING

Indicates a hazard with a medium level of risk which, if not avoided, could result in death or serious injury.

CAUTION

Indicates a hazard with a low level of risk which, if not avoided, could result in minor or moderate injury.

NOTE

Additional information.

Target group

DANGER

These instructions are exclusively intended for qualified contractors and authorized installers.

- Work on the refrigerant circuit with flammable refrigerant in safety group A3 may only be carried out by authorized heating contractors. These heating contractors must be trained in accordance with EN 378 Part 4 or IEC 60335-2-40, Section HH. The certificate of competence from an industry accredited body is required.
- Brazing/soldering work on the refrigerant circuit may only be carried out by personnel certified in accordance with ISO 13585 and AD 2000, Datasheet HP 100 R. And only contractors qualified and certified for the processes can perform brazing/soldering work. The work must fall within the range of applications purchased and be carried out in accordance with the prescribed procedures. Soldering/brazing work on accumulator connections requires certification of personnel and processes by a notified body according to the Pressure Equipment Directive (2014/68/EU).
- Work on electrical equipment may only be carried out by a qualified electrician.
- Before initial commissioning, all safety-related points must be checked by the particular certified heating contractors. The system must be commissioned by the system installer or a qualified person authorized by the installer.

Safety precaution about the appliances using flammable refrigerant

WARNING





- The following precautions should be complied with when installation, service, maintenance and repair, and decommissioning of appliances using flammable refrigerant.

General

This appliance employed A3 flammable refrigerant R290.

The appliance shall be stored so as to prevent mechanical damage from occurring.

Symbols

	WARNING	This symbol shows that this appliance used a flammable refrigerant. If the refrigerant is leaked and exposed to an external ignition source, there is a risk of fire.
	CAUTION	This symbol shows that the manual should be read carefully.
	CAUTION	This symbol shows that only a competent service personnel should be handling this equipment with reference to the technical manual.
	CAUTION	This symbol shows that information is available such as the operating manual or installation manual.

WARNING

- Do not use means to accelerate the defrosting process or to clean, other than those recommended by the manufacturer.
- The appliance shall be stored in a room without continuously operating ignition sources (for example: open flames, an operating gas appliance or an operating electric heater).
 - Do not pierce or burn.
 - Be aware that refrigerants might not contain an odour.

Installation

① Qualification of workers

WARNING

- Refer to Target group described in chapter 1 SAFETY PRECAUTION.
- Every working procedure that affects safety means shall only be carried out by competent persons.

- Examples for such working procedures are:
- breaking into the refrigerating circuit;
 - opening of sealed components;
 - opening of ventilated enclosures.

② General

WARNING

- Protection devices, piping and fittings shall be protected as far as possible against adverse environmental effects, for example the danger of water collecting and freezing in relief pipes or the accumulation of dirt and debris;
- Provision shall be made for expansion and contraction of long runs of piping;
- Piping in refrigerating systems shall be so designed and installed as to minimize the likelihood of hydraulic shock damaging the system;
- Steel pipes and components shall be protected against corrosion with a rustproof coating before applying any insulation;

Information on servicing

① General

CAUTION

Servicing shall be performed only as recommended by the manufacturer.

② Checks to the area

Prior to beginning work on systems containing flammable refrigerants, safety checks are necessary to ensure that the risk of ignition is minimised. For repair to the refrigerating system, DD.4.3 to DD.4.7 shall be completed prior to conducting work on the system.

③ Work procedure

Work shall be undertaken under a controlled procedure so as to minimise the risk of a flammable gas or vapour being present while the work is being performed.

④ General work area

All maintenance staff and others working in the local area shall be instructed on the nature of work being carried out. Work in confined spaces shall be avoided.

The area around the workspace shall be sectioned off. Ensure that the conditions within the area have been made safe by control of flammable material.

⑤ Checking for presence of refrigerant

The area shall be checked with an appropriate refrigerant detector prior to and during work, to ensure the technician is aware of potentially toxic or flammable atmospheres. Ensure that the leak detection equipment being used is suitable for use with all applicable refrigerants, i.e. non-sparking, adequately sealed or intrinsically safe.

⑥ Presence of fire extinguisher

If any hot work is to be conducted on the refrigerating equipment or any associated parts, appropriate fire

extinguishing equipment shall be available to hand. Have a dry powder or CO₂ fire extinguisher adjacent to the charging area.

⑦ No ignition sources

No person carrying out work in relation to a refrigerating system which involves exposing any pipe work shall use any sources of ignition in such a manner that it can lead to the risk of fire or explosion. All possible ignition sources, including cigarette smoking, should be kept sufficiently far away from the site of installation, repairing, removing and disposal, during which refrigerant can possibly be released to the surrounding space. Prior to work taking place, the area around the equipment is to be surveyed to make sure that there are no flammable hazards or ignition risks. "No Smoking" signs shall be displayed.

⑧ Ventilated area

Ensure that the area is in the open or that it is adequately ventilated before breaking into the system or conducting any hot work. A degree of ventilation shall continue during the period that the work is carried out. The ventilation should safely disperse any released refrigerant and preferably expel it externally into the atmosphere.

⑨ Checks to the refrigerating equipment

Where electrical components are being changed, they shall be fit for the purpose and to the correct specification. At all times the manufacturer's maintenance and service guidelines shall be followed. If in doubt, consult the manufacturer's technical department for assistance.

The following checks shall be applied to installations using flammable refrigerants:

- the refrigerant charge is in accordance with the room size within which the refrigerant containing parts are installed;
- the ventilation machinery and outlets are operating adequately and are not obstructed;
- if an indirect refrigerating circuit is being used, the secondary circuit shall be checked for the presence of refrigerant;
- marking to the equipment continues to be visible and legible. Markings and signs that are illegible shall be corrected;
- refrigerating pipe or components are installed in a position where they are unlikely to be exposed to any substance which can corrode refrigerant containing components, unless the components are constructed of materials which are inherently resistant to being corroded or are suitably protected against being so corroded.

⑩ Checks to electrical devices

Repair and maintenance to electrical components shall include initial safety checks and component inspection procedures. If a fault exists that could compromise safety, then no electrical supply shall be connected to the circuit until it is satisfactorily dealt with. If the fault cannot be corrected immediately but it is necessary to continue operation, an adequate temporary solution shall be used. This shall be reported to the owner of the equipment so all parties are advised.

Initial safety checks shall include:

- that capacitors are discharged: this shall be done in a safe manner to avoid possibility of sparking;
- that no live electrical components and wiring are exposed while charging, recovering or purging the system;
- that there is continuity of earth bonding.

Sealed electrical components

WARNING

Sealed electrical components shall not be repaired.

Cabling

Check that cabling will not be subject to wear, corrosion, excessive pressure, vibration, sharp edges or any other adverse environmental effects. The check shall also take into account the effects of aging or continual vibration from sources such as compressors or fans.

Detection of flammable refrigerants

Under no circumstances shall potential sources of ignition be used in the searching for or detection of refrigerant leaks. A halide torch (or any other detector using a naked flame) shall not be used.

The following leak detection methods are deemed acceptable for all refrigerant systems.

Electronic leak detectors may be used to detect refrigerant leaks but, in the case of flammable refrigerants, the sensitivity can be inadequate, or can need re-calibration. (Detection equipment shall be calibrated in a refrigerant-free area.) Ensure that the detector is not a potential source of ignition and is suitable for the refrigerant used. Leak detection equipment shall be set at a percentage of the LFL of the refrigerant and shall be calibrated to the refrigerant employed, and the appropriate percentage of gas (25 % maximum) is confirmed.

Leak detection fluids are also suitable for use with most refrigerants but the use of detergents containing chlorine shall be avoided as the chlorine can react with the refrigerant and corrode the copper pipe-work.

NOTE Examples of leak detection methods are

- bubble method,
- fluorescent agent method.

If a leak is suspected, all naked flames shall be removed/extinguished.

If a leakage of refrigerant is found which requires brazing, all of the refrigerant shall be recovered from the system, or isolated (by means of shut-off valves) in a part of the system remote from the leak. Removal of refrigerant shall be according to Clause 8.

CAUTION

Oxygen free nitrogen (OFN) shall then be purged through the system both before and during the brazing process.

Refrigerant removal and circuit evacuation

When breaking into the refrigerant circuit to make repairs

- or for any other purpose
- conventional procedures shall be used. However, for flammable refrigerants it is important that best practice is followed since flammability is a consideration. The following procedure shall be adhered to:
 - safely remove refrigerant following local and national regulations;
 - evacuate;
 - purge the circuit with inert gas (optional for A2L);
 - evacuate (optional for A2L);
 - continuously flush with inert gas when using flame to open circuit;
 - open the circuit.

The refrigerant charge shall be recovered into the correct recovery cylinders.

CAUTION

An inert gas, specifically, is dry oxygen free nitrogen(OFN).

The system shall be “flushed” with OFN to render the unit safe. This process may need to be repeated several times.

Compressed air or oxygen shall not be used for purging refrigerant systems.

Purging of the refrigerant circuit shall be achieved by breaking the vacuum in the system with inert gas and continuing to fill until the working pressure is achieved, then venting to atmosphere, and finally pulling down to a vacuum. This process shall be repeated until no refrigerant is within the system. The system shall be vented down to atmospheric pressure to enable work to take place.

CAUTION

This operation is absolutely vital if brazing operations on the pipework are to take place.

Ensure that the outlet of the vacuum pump is not close to any potential ignition sources and that ventilation is available.

Charging procedures

In addition to conventional charging procedures, the following requirements shall be followed.

- Ensure that contamination of different refrigerants does not occur when using charging equipment. Hoses or lines shall be as short as possible to minimise the amount of refrigerant contained in them.
- Cylinders shall be kept in an appropriate position according to the instructions.
- Ensure that the refrigerating system is earthed prior to charging the system with refrigerant.
- Label the system when charging is complete (if not already labelled).
- Extreme care shall be taken not to overfill the refrigerating system.

Prior to recharging the system, it shall be pressure-tested with the appropriate purging gas. The system shall be leak-tested on completion of charging but prior to commissioning. A follow up leak test shall be carried out prior to leaving the site.

Decommissioning

Before carrying out this procedure, it is essential that the technician is completely familiar with the equipment and all its detail. It is recommended good practice that all refrigerants are recovered safely. Prior to the task being carried out, an oil and refrigerant sample shall be taken

in case analysis is required prior to re-use of recovered refrigerant. It is essential that electrical power is available before the task is commenced.

- 1) Become familiar with the equipment and its operation.
- 2) Isolate system electrically.
- 3) Before attempting the procedure, ensure that:
 - a) mechanical handling equipment is available, if required, for handling refrigerant cylinders;
 - b) all personal protective equipment is available and being used correctly;
 - c) the recovery process is supervised at all times by a competent person;

d) recovery equipment and cylinders conform to the appropriate standards.

4) Pump down refrigerant system, if possible.

5) If a vacuum is not possible, make a manifold so that refrigerant can be removed from various parts of the system.

6) Make sure that the cylinder is situated on the scales before recovery takes place.

7) Start the recovery machine and operate in accordance with instructions.

8) Do not overfill cylinders (no more than 80 % volume liquid charge).

9) Do not exceed the maximum working pressure of the cylinder, even temporarily.

10) When the cylinders have been filled correctly and the process completed, make sure that the cylinders and the equipment are removed from site promptly and all isolation valves on the equipment are closed off.

11) Recovered refrigerant shall not be charged into another refrigerating system unless it has been cleaned and checked.

Labelling

Equipment shall be labelled stating that it has been de-commissioned and emptied of refrigerant. The label shall be dated and signed. For appliances containing flammable refrigerants, ensure that there are labels on the equipment stating the equipment contains flammable refrigerant.

Recovery

When removing refrigerant from a system, either for servicing or decommissioning, it is required to follow good practice so that all refrigerants are removed safely.

When transferring refrigerant into cylinders, ensure that only appropriate refrigerant recovery cylinders are employed. Ensure that the correct number of cylinders for holding the total system charge is available. All cylinders to be used are designated for the recovered refrigerant and labelled for that refrigerant (i.e. special cylinders for the recovery of refrigerant). Cylinders shall be complete with pressure-relief valve and associated shut-off valves in good working order. Empty recovery cylinders are evacuated and, if possible, cooled before recovery occurs.

The recovery equipment shall be in good working order with a set of instructions concerning the equipment that is at hand and shall be suitable for the recovery of the flammable refrigerant. Consult manufacturer if in doubt. In addition, a set of calibrated weighing scales shall be available and in good working order. Hoses shall be complete with leak-free disconnect couplings and in good condition. The recovered refrigerant shall be processed according to local legislation in the correct recovery cylinder, and the relevant waste transfer note arranged. Do not mix refrigerants in recovery units and especially not in cylinders.

If compressors or compressor oils are to be removed, ensure that they have been evacuated to an acceptable level to make certain that flammable refrigerant does not remain within the lubricant. The compressor body shall not be heated by an open flame or other ignition sources to accelerate this process. Draining of oil from a system shall be carried out safely.

Intended use

There is a risk of injury or death to the user or others, or of damage to the product and other property in the event of improper or unintended use.

The product is the outdoor unit of an air-to-water heat pump with monoblock design.

The product uses the outdoor air as a heat source and can be used to heat a residential building and generate domestic hot water.

The air that escapes from the product must be able to flow out freely, and must not be used for any other purposes.

The product is only intended for outdoor installation.

The product is intended exclusively for domestic use, which means that the following places are not appropriate for installation:

- Where there is mist of mineral oil or oil spray or vapors. Plastic parts may deteriorate, and cause joint loose and leakage of water.
- Where corrosive gases (such as sulfurous acid gas) are produced, or corrosion of copper pipes or soldered parts may cause leakage of refrigerant.
- Where there is machinery which emits massive electromagnetic waves. Enormous electromagnetic waves can disturb the control of the system and cause equipment malfunction.
- Where flammable gases may leak, carbon fiber or ignitable dust is suspended in the air or volatile flammables such as paint thinner or gasoline are handled. These types of gases might cause a fire.
- Where the air contains high levels of salt such as a location near the ocean.
- Where voltage fluctuates a lot, such as a location in a factory.
- In vehicles or vessels.
- Where acidic or alkaline vapors are present.

Intended use includes the following:

- Observance of the operating instructions included for the product and any other installation components.
- Compliance with all inspection and maintenance conditions listed in the instructions.
- Installing and setting up the product in accordance with the product and system approval.
- Installation, commissioning, inspection, maintenance and troubleshooting by qualified contractors and authorized installers.

Intended use also covers installation in accordance with the IP code.

This appliance can be used by children aged from 8 years and above and persons with reduced physical, sensory or mental capabilities or lack of experience and knowledge provided that they have been given supervision or instruction concerning the use of the appliance in a safe way and understand the hazards involved. Children should not play with the appliance. Cleaning and maintenance should not be made by children without supervision

Any other use that is not specified in these instructions, or use beyond that specified in this document, should be considered as improper use. Any direct commercial or industrial use is also deemed to be improper.

CAUTION

Improper use of any kind is prohibited.

- Do not rinse the unit.
- Do not place any object or equipment on top of the unit (top plate).
- Do not climb, sit or stand on top of the unit.

Regulations to be observed

- 1) National installation regulations.
- 2) Statutory regulations for the prevention of accidents.
- 3) Statutory regulations for environmental protection.
- 4) Statutory requirements for pressure equipment: Pressure Equipment Directive 2014/68/EU.
- 5) Codes of practice of the relevant trade associations.
- 6) Relevant country-specific safety regulations.
- 7) Applicable regulations and guidelines for operation, service, maintenance, repair and safety of cooling, air conditioning and heat pump systems containing flammable and explosive refrigerant.

Safety instructions for working on the system

The outdoor unit contains flammable refrigerant R290 (propane C₃H₈). In case of a leak, the escaping refrigerant may form a flammable or explosive atmosphere in the ambient air. A safety zone is defined in the immediate vicinity of the outdoor unit, in which special rules apply when work is performed on the appliance. See section "Safety zone".

Working in the safety zone

DANGER

Risk of explosion: Refrigerant leak may form a flammable or explosive atmosphere in the ambient air.

Take the following measures to prevent fire and explosion in the safety zone:

- Keep ignition sources away, including naked flames, plug sockets, hot surfaces, light switches, lamps, electrical devices not free of ignition sources, mobile devices with integrated batteries (such as mobile phones and fitness watches).
- Do not use any sprays or other combustible gases in the safety zone.

CAUTION

Permissible tools: All tools for working in the safety zone must be designed and explosion-protected in accordance with the applicable standards and regulations for refrigerant in safety groups A2L and A3, such as brushless machines (cordless disposal containers, installation aids, and screwdrivers), extraction equipment, vacuum pumps, conductive hoses, and mechanical tools of non-sparking material.

CAUTION

The tools must also be suitable for the pressure ranges in use. Tools must be in perfect maintenance conditions.

- The electrical equipment must meet the requirements for areas at risk of explosion, zone 2.
- Do not use flammable materials such as sprays or other flammable gases.
- Before starting work, discharge static electricity by touching earthed objects, such as heating or water pipes.
- Do not remove, block or bridge safety equipment.
- Do not make any changes: Do not modify the outdoor unit, inlet/ outlet lines, electrical connections/ cables or the surroundings. Do not remove any components or seals.

Working on the system

Switch off the power supply for the unit (including all affiliated parts) at a separate fuse or mains isolator. Check and ensure that the system is no longer live.

CAUTION

In addition to the control circuit there may be several power circuits.

DANGER

Contact with live components can result in severe injuries. Some components on PCBs remain live even after the power supply has been switched off. Prior to removing covers from the appliances, wait at least 4 minutes until the voltage has completely dropped out.

- Safeguard the system against re-connection.
- Wear suitable personal protective equipment when carrying out any work.
- Do not touch any switch or electrical parts with wet fingers. It may cause electrical shock and compromise the system.

DANGER

Hot surfaces and fluids can result in burns or scalding. Cold surfaces may cause frostbite.

- Prior to servicing or maintenance tasks, switch off and allow the equipment to cool down or warm up.
- Do not touch hot or cold surfaces on the appliance, fittings or pipework.

NOTE

Electronic assemblies can be damaged by electrostatic discharge. Before beginning work, touch earthed objects, such as heating or water pipes, to discharge any static.

Safety work area and temporary flammability zones.

CAUTION

When working on systems using flammable refrigerants, the technician should consider certain locations as “temporary flammable zones”. These are normally regions where at least some emission of refrigerant is anticipated to occur during the normal working procedures, such as recovery, charging and evacuation, typically where hoses may be connected or disconnected. The technician should ensure three meters safety working area (radius of the unit) in case of any accidental release of refrigerant that forms a flammable mixture with air.

Working on the refrigerant circuit

R290 refrigerant (propane) is an air displacing, colorless, flammable, odorless gas which forms explosive mixtures with air. Refrigerant drained must be properly disposed of by authorized contractors.

- Perform the following measures before beginning work on the refrigerant circuit:

- Check the refrigerant circuit for leaks.
- Ensure very good ventilation especially in the floor area and maintain this for the duration of the work.
 - Secure the area surrounding the work area.
 - Inform the following persons of the type of work to be carried out: – All maintenance personnel – All persons in the vicinity of the system.
 - Inspect the area immediately around the heat pump for flammable materials and ignition sources: Remove all flammable materials and ignition sources.
 - Before, during and after the work, check the surrounding area for escaping refrigerant using an explosion-proof refrigerant detector suitable for R290. This refrigerant detector must not generate any sparks and must be suitably sealed.
 - A CO₂ or powder extinguisher must be available in the following cases: – Refrigerant is being drained. – Refrigerant is being topped up. – Soldering or welding work is in progress.
 - Display signs prohibiting smoking.

DANGER

Escaping refrigerant can lead to fires and explosions that result in very serious injuries or death.

- Do not drill or apply heat to a refrigerant circuit filled with refrigerant.
- Do not operate Schrader valves unless a fill valve or extraction equipment is attached.
- Take measures to prevent electrostatic charge.
- Do not smoke. Avoid naked flames and sparks. Never switch lights or electrical appliances on or off in environments with naked flames or sparks.
- Components that contain or contained refrigerant must be labeled, and stored in well ventilated areas in accordance with the applicable regulations and standards.

DANGER

Direct contact with liquid or gaseous refrigerant can cause serious damage to health such as frostbite and/or burns. There is a risk of asphyxiation if liquid or gaseous refrigerant is breathed in.

- Prevent direct contact with liquid or gaseous refrigerant.
- Wear personal protective equipment when handling liquid or gaseous refrigerant.
- Never breathe in any refrigerant vapor.

DANGER

Refrigerant is under pressure: Mechanical loading of lines and components can cause leaks in the refrigerant circuit. Do not apply loads to the lines or components, such as supporting or placing tools.

DANGER

Hot or cold metallic surfaces of the refrigerant circuit may cause burns or frostbite in case of skin contact. Wear personal protective equipment to protect against burns or frostbite.

NOTE

Hydraulic components may freeze during refrigerant removal. Drain heating water from the heat pump beforehand.

DANGER

Damage to the refrigerant circuit can cause refrigerant to enter the hydraulic system. After completion of the work, vent the hydraulic system correctly. When doing so, ensure the area is sufficiently ventilated.

Installation General

- Be sure to use only specified accessories and parts for installation. Failure to use specified parts may result in water leakage, electric shocks, fires, or the unit falling from its mount.
- Install the unit on a foundation that can withstand its weight. Insufficient physical strength may cause the unit to fall and possible injury.
- Perform specified installation work with full consideration of strong wind, hurricanes, or earthquakes. Improper installation may result in accidents due to equipment falling.
- Earth the unit and install a ground fault circuit interrupter in accordance with local regulations. Operating the unit without a proper ground fault circuit interrupter may cause electric shocks and fires.
- Install the power cable at least 3 feet (1 meter) away from televisions or radios to prevent interference or noise. (Depending on the radio waves, a distance of 3 feet (1 meter) may not be sufficient to eliminate the noise.)
- Any damaged power cord must be replaced by the manufacturer or its service agent or a similarly qualified person in order to avoid a hazard.
- This appliances can not to be used at altitudes 2 000 m and above.

CAUTION

For the primary water circulation loop:

- 1) Do not install any air vent valve in the indoor side. If the air vent valve has to be installed in the indoor side, no ignition sources exist around the air vent valve.
 - 2) Make sure the outlet of the indoor safety valve leads to the outdoor side and no ignition sources exist around the outlet of safety valve.
- For the secondary water circulation loop (e.g. DHW loop):

Follow the general rules for the installation of air vent valve and safety valve.

Two situations should be considered for outdoor installations to prevent damage to the system, releases, and undesirable consequences:

- Where the equipment is located in an area accessible by members of the public, and.
- Where the equipment is located in a restricted area, with access to authorized persons only.

DANGER



Open flames, fires, open ignition sources and smoking are prohibited.

DANGER



Inflammable matters are prohibited.

Freezing protection

CAUTION

Freezing can cause damage to the heat pump.

- Thermally insulate all the hydraulic lines.
- Antifreeze can be filled in the secondary circuit in accordance with local regulations and standards.

Repair work

CAUTION

Repairing components that fulfil a safety function can compromise the safe operation of the system.

- Replace faulty components only with genuine spare parts from the manufacturer.
- Do not undertake any repairs on the inverter. Replace the inverter if there is a defect.
- Repair work should not be performed in the field. Repair the unit in a specified location.

Auxiliary components, spare and wearing parts

CAUTION

Spare and wearing parts that have not been tested together with the system can compromise the function of the system. Installing non-authorized components and making non-approved modifications or conversions can compromise the safety and may invalidate our warranty. Only use original spare parts supplied or approved by the manufacturer for replacement.

Safety instructions for operating the system

What to do if refrigerant leaks

WARNING

To avoid potential risk from refrigerant leak, always keep 2 meters away from the unit, especially for kids, no matter the unit is in operation or not.

DANGER

Refrigerant leak can lead to fires and explosions that result in very serious injuries or death. Breathing in refrigerant may cause asphyxiation.

- Ensure very good ventilation especially in the floor area of the outdoor unit.
- Do not smoke. Avoid naked flames and sparks. Never switch lights or electrical appliances on or off in environments with naked flames or sparks.
- Evacuate any people from the dangerous zone.
- From a safe position, switch off the power supply for all system components.
- Remove ignition sources from the dangerous zone.
- The system user should know that no ignition source may be brought into the dangerous zone during the repair.
- Repair work must be carried out by an authorized contractor.
- Do not recommission the system until it is repaired.

CAUTION

Direct contact with liquid or gaseous refrigerant can cause serious damage to health, e.g. frostbite and/or burns. Breathing in liquid or gaseous refrigerant may cause asphyxiation.

- Prevent direct contact with liquid or gaseous refrigerant.
- Never breathe in refrigerant vapors.

What to do if water leaks

DANGER

If water leaks from the appliance, an electric shock may occur. Switch off the heating system at the external isolator (e.g. fuse box, domestic distribution board).

DANGER

If water leaks from the appliance, scalding may occur. Never touch hot water.

What to do if the outdoor unit ices up

CAUTION

A build-up of ice in the condensate pan and in the fan area of the outdoor unit can cause damage to the equipment.

- Do not use mechanical items/aids to remove ice.
- Before using electrical heating appliances, check the refrigerant circuit for leaks with a suitable measuring device. The heating appliance should not be a source of ignition, and must meet the requirements of EN 60335-2-30.
- If ice regularly builds up on the outdoor unit (e.g. in areas where frost and heavy fog occur frequently), install an electric ribbon heater in the condensate pan (field supply or factory-fitted device if such part is selected).

Safety instructions for storage of the outdoor unit

The outdoor unit is charged at the factory with refrigerant R290 (propane).

DANGER

Refrigerant leak can lead to fires and explosions that result in very serious injuries or death. Breathing in refrigerant may cause asphyxiation. Store the outdoor unit in the following conditions:

- An explosion prevention plan must be in place for storage.
- Ensure the storage location is well ventilated.
- Keep away from ignition sources (avoid exposure to heat and smoking).
- Temperature range for storage: -25°C to 70°C
- Only store the outdoor unit in its original protective packaging from the factory.
- Protect the outdoor unit against damage.
- The maximum number of outdoor units that may be stored in one place is determined according to local conditions.

CAUTION

A fire with R290 should only be fought with CO₂ or dry powder extinguishers.

Disposal

This equipment uses flammable refrigerants. The disposal of the equipment must comply with national regulations.

Do not dispose this product as unsorted municipal waste. Collection of such waste separately for special treatment is necessary.

- Do not dispose of electrical appliances as unsorted municipal waste, and use separate collection facilities.
- Contact your local government for information regarding the collection systems available.

If electrical appliances are disposed of in landfills or dumps, hazardous substances can leak into the groundwater and get into the food chain, damaging your health and well-being.



WARNING: Risk of fire

2 GENERAL INTRODUCTION

2.1 Documentation

- Always observe all the operating and installation instructions included with the system components.
- Hand these instructions and all other applicable documents to the end user.
- Scan the QR code on the right for other languages.

This document is part of a documentation set. The complete set consists of:

Document	Content	Format
Installation Manual (this manual)	Brief installation instructions	Paper (in the box next to the outdoor unit)
Installation, Operation and Maintenance Manual	Preparation for the installation, good practices...(more information contained, for installers and advanced users only)	Digital files. Scan the QR code on the right.
Operation Manual (wired controller)	Quick guide for basic usage	Paper (in the box next to the outdoor unit)
Technical Data Manual	Performance data and ERP information	Paper (in the box next to the outdoor unit)



Scan the QR code to read the manual in different languages



Installation, Operation and Maintenance Manual

Online Tools (APP and websites)

Refer to the OPERATION MANUAL for more information.

For the terms and abbreviation, see Annex C.

2.2 Validity of the instructions

These instructions apply only to:

Unit	1-phase							3-phase			
	4	6	8	10	12	14	16	12	14	16	
Net weight (kg)	90 (95 *)		117 (122 *)		135 (140 *)			137 (142 *)			
Wiring specification (mm ²) - main power supply	2.5-4	2.5-4	4-6	4-6	6-10	6-10	6-10	2.5-4	2.5-4	2.5-4	
Minimum flow rate required (m ³ /h)	0.4	0.4	0.4	0.4	0.7	0.7	0.7	0.7	0.7	0.7	
Capacity of backup heater	3 kW (1-phase)		3 kW (1-phase) or 6 kW (3-phase) or 9 kW (3-phase)								
Wiring specification (mm ²) - backup heater power supply	2.5-4	2.5-4	2.5-4	2.5-4	2.5-4	2.5-4	2.5-4	2.5-4	2.5-4	2.5-4	

* With a backup heater

The standard version does not include a backup heater, but it can be added as an optional feature for specific units. There are two types of backup heater, internal and external. Set dip switch correctly for internal and external application (refer to Wiring Diagram).

2.3 Unpacking

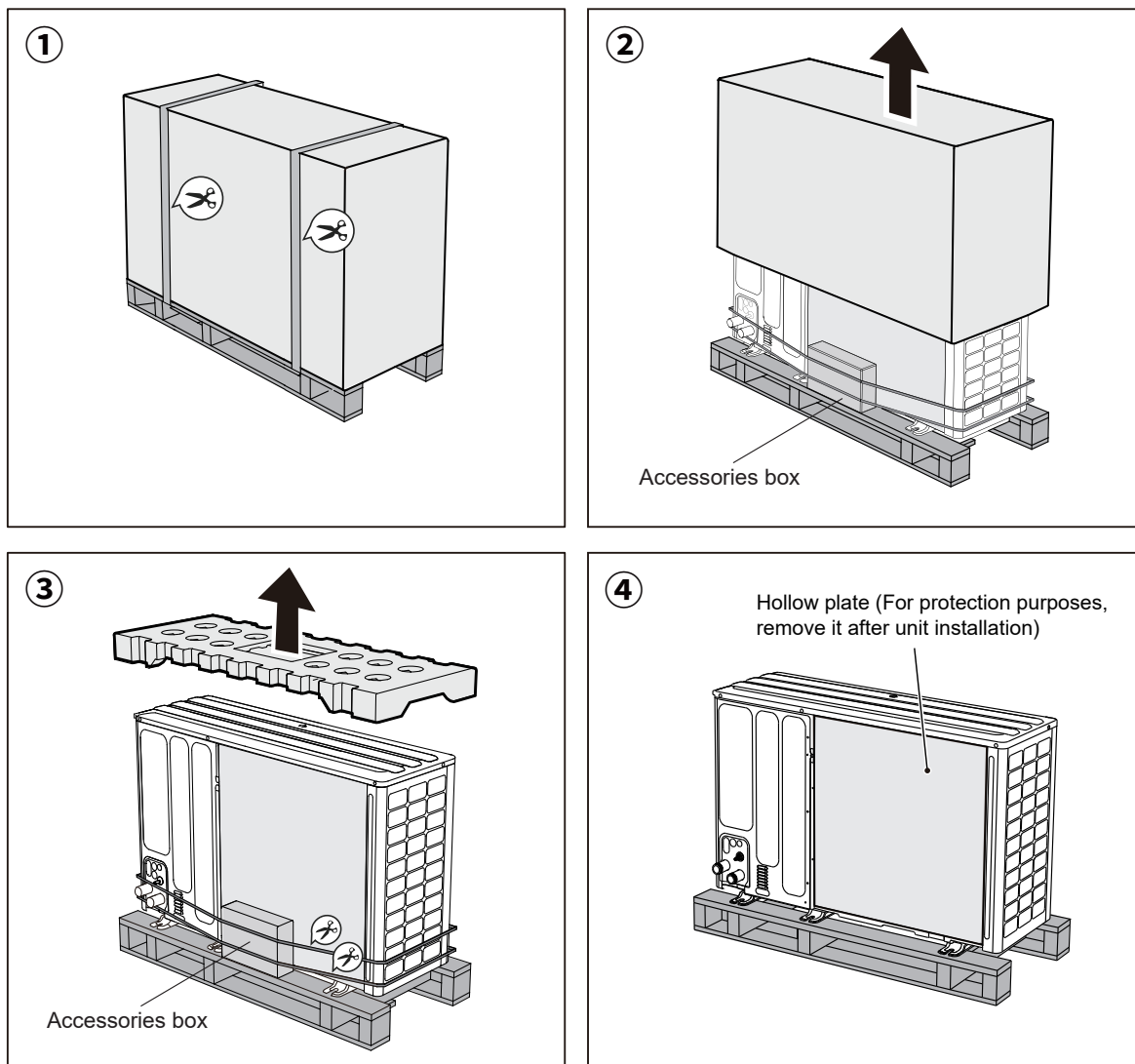









For the accessories box, see 2.4 Accessories of the Unit for more details.

NOTE

8-16 kW units are illustrated. All units apply to the same principle.

2.4 Accessories of the unit

Accessories of the unit			
Name	Illustration	Quantity	Specification
Installation Manual (this manual)		1	-
Technical Data Manual		1	-
Operation Manual		1	-
Y- Type Strainer		1	4-6 kW:G 1"
			8-16 kW:G 1 1/4"

Wired Controller Box		1	-
Thermistor (T5 or Tw2 or Tbt)		1	10 m
Drain Joint		1	Φ 32
Energy Label		1	-
Tie Wrap		4	-
Paper Edge Protector		1	A
		1	B
Network Matching Resistor		1	-

For more options supplied by the manufacturer, see the INSTALLATION, OPERATION AND MAINTENANCE MANUAL for further information.

2.5 Transportation

2.5.1 Dimensions and barycenter

The illustrations below are for 8-16 kW units. The principle is the same for 4-6 kW units. A, B, and C indicate the locations of barycenter.

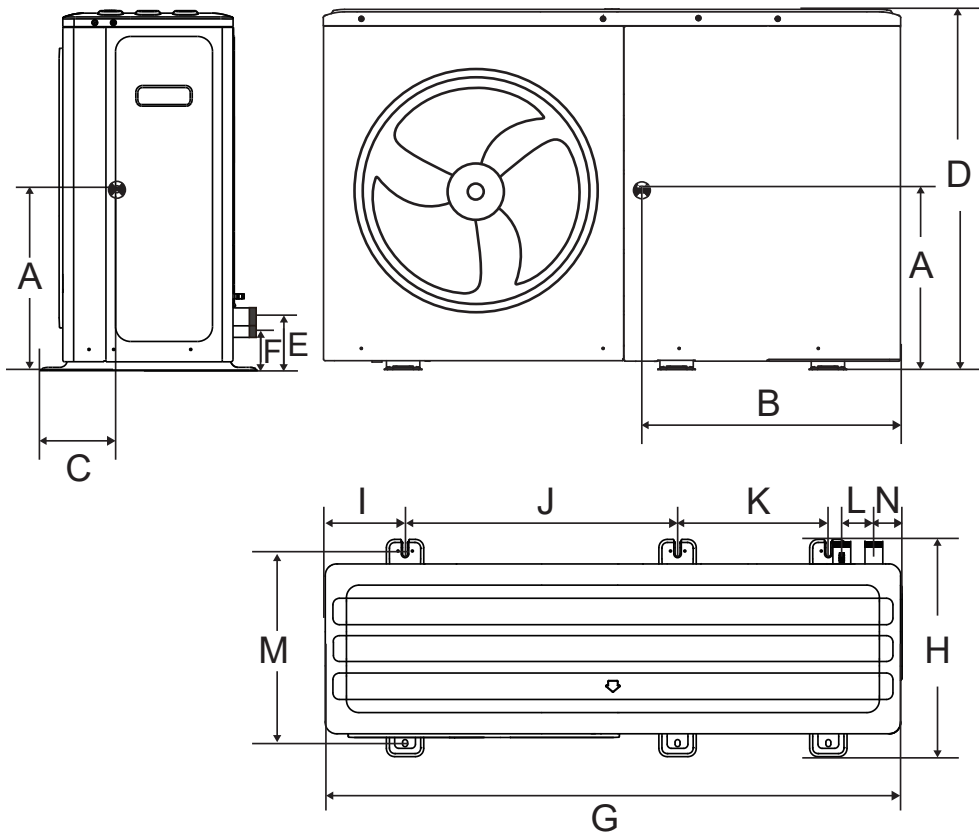

(mm)

Model	A	B	C	D	E	F	G	H	I	J	K	L	M	N
1 phase 4/6 kW	333	528	210	717	91	91	1 299	426	121	644	379	90	375	71
1 phase 8/10 kW	360	550	234	865	129	100	1 385	523	192	656	363	77	456	68
1 phase 12/14/16 kW	415	715	200	865	129	100	1 385	523	192	656	363	77	456	68
3 phase 12/14/16 kW	415	715	200	865	129	100	1 385	523	192	656	363	77	456	68

2.5.2 Manual transportation

⚠ WARNING

Risk of injury from lifting a heavy weight.
Lifting weights that are too heavy may cause injury to the spine, for example.

- Note the weight of the product.
- Have four people lift the product.

1. Take into consideration the weight distribution during transportation. The product is significantly heavier on the compressor side than on the fan motor side. (see content above for the barycenter)
2. Protect the casing sections from damage. Using paper edge protector under the unit when lift the unit.
3. After transportation, remove the transport straps.
4. During transportation, do not tilt the product to an angle larger than 45°.

2.5.3 Lifting

Use lifting tools with transport straps or a suitable hand truck.

Unit on the pallet:

Pass the transport straps through the holes on the left and right sides of the pallet properly.

No pallet under the unit:

The transport straps can be fitted into the dented position at the base frame that are made specifically for this purpose. Using paper edge protector under the unit when lifting the unit.

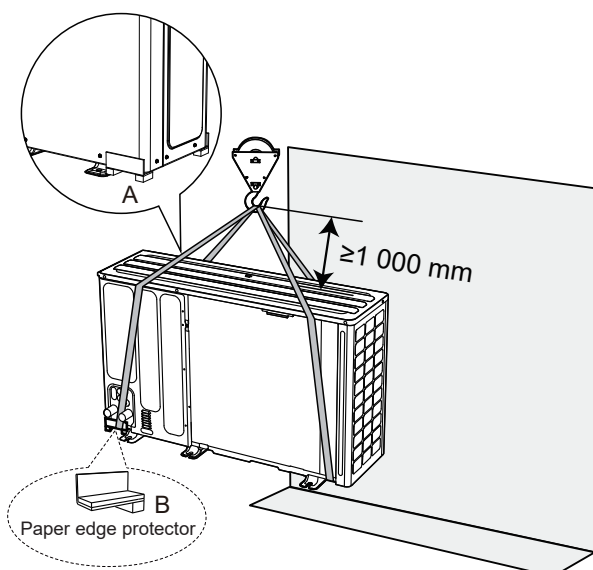

⚠ CAUTION

The barycenter of the product and the hook should be kept in a straight line in the vertical direction to prevent excessive tilting.

2.6 Parts to be removed

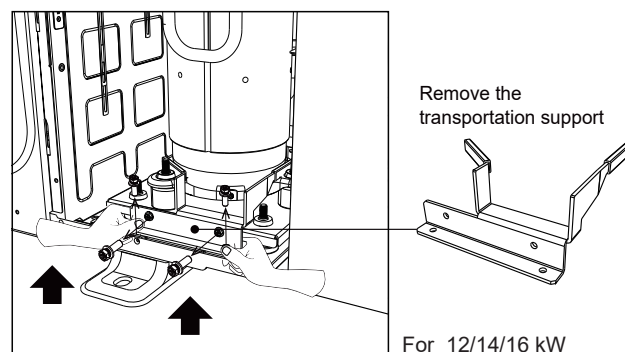
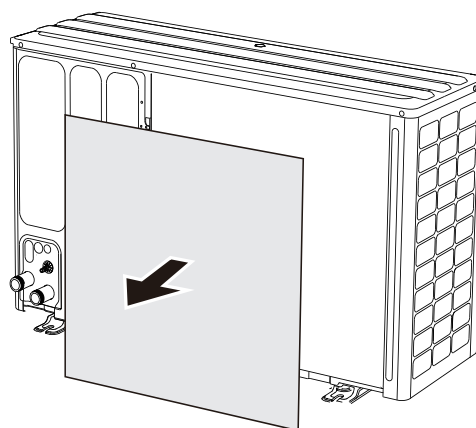

To open the unit, see 6.1 Opening the Electrical Box Cover.

⚠ CAUTION

Move the parts above after unit installation.

2.7 Operating range

In cooling mode, the product works at an outdoor temperature of -5 °C to 46 °C.

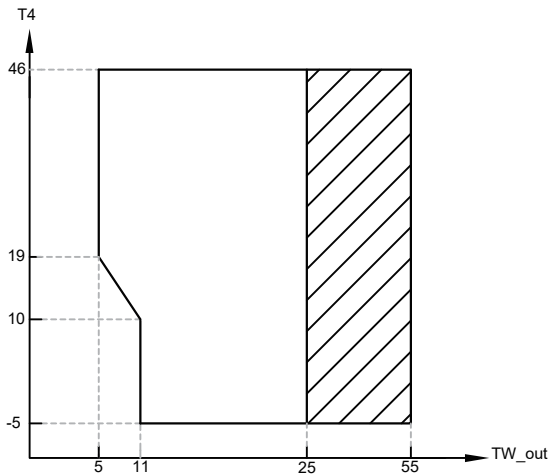

Operation range by heat pump with possible limitation and protection.

TW_out: leaving water temperature
T4: outdoor ambient temperature

In heating mode, the product works at an outdoor temperature of -25 °C to 35 °C

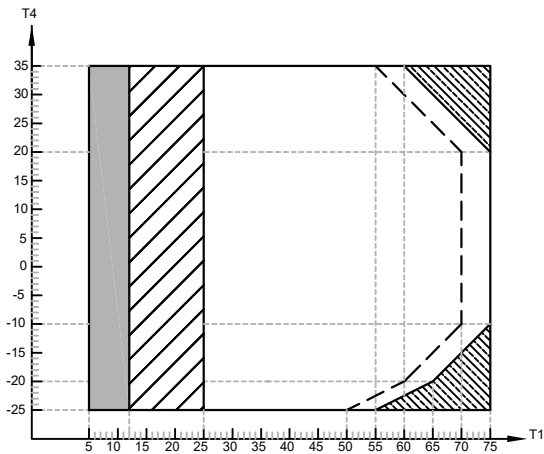

If IBH/AHS setting is valid, only IBH/AHS turns on;
 If IBH/AHS setting is invalid, only heat pump turns on, limitation and protection may occur during heat pump operation.

Operation range by heat pump with possible limitation and protection.

Heat pump turns off, only IBH/AHS turns on.

--- Maximum inlet water temperature line for heat pump operation.

T1: leaving water temperature
T4: outdoor ambient temperature

In DHW mode, the product works at an outdoor temperature of -25 °C to 46 °C

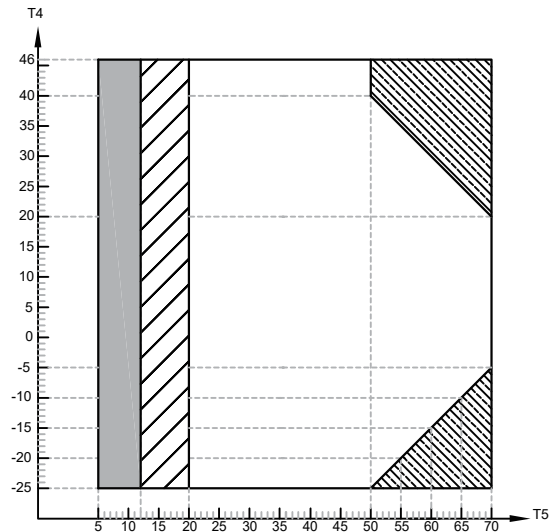

If TBH/IBH/AHS setting is valid, only TBH/IBH/AHS turns on;
 If TBH/IBH/AHS setting is invalid, only heat pump turns on, limitation and protection may occur during heat pump operation.

Operation range by heat pump with possible limitation and protection.

Heat pump turns off, only TBH/IBH/AHS turns on.

T5: DHW tank temperature
T4: outdoor ambient temperature

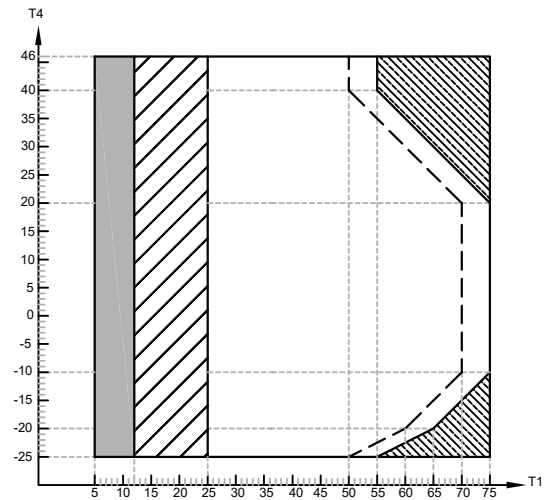

If IBH/AHS setting is valid, only IBH/AHS turns on;
 If IBH/AHS setting is invalid, only heat pump turns on, limitation and protection may occur during heat pump operation.

Operation range by heat pump with possible limitation and protection.

Heat pump turns off, only IBH/AHS turns on.

--- Maximum inlet water temperature line for heat pump operation.

T1: leaving water temperature
T4: outdoor ambient temperature

2.8 Hydraulic module

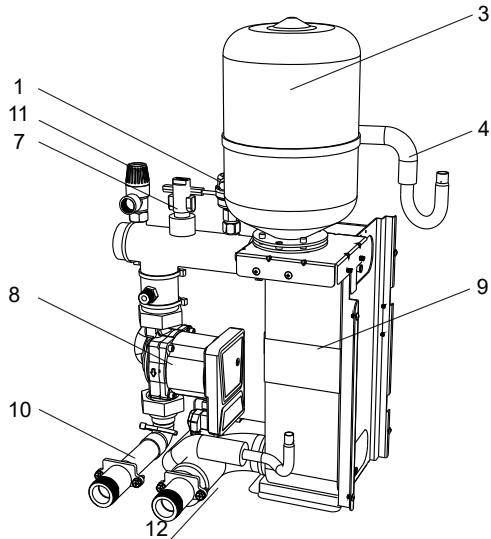

4/6 kW unit without a backup heater

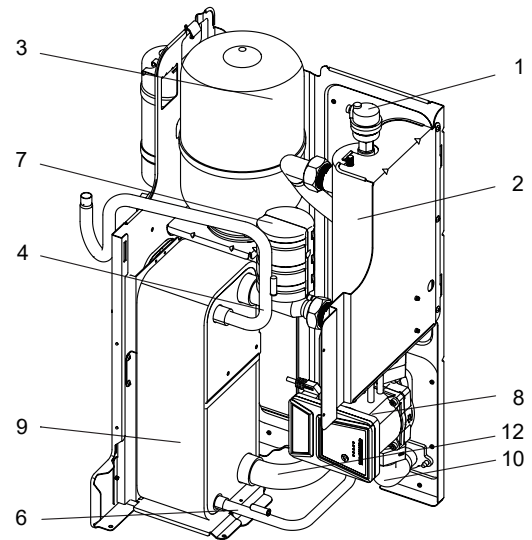

4/6 kW unit with a backup heater (optional)

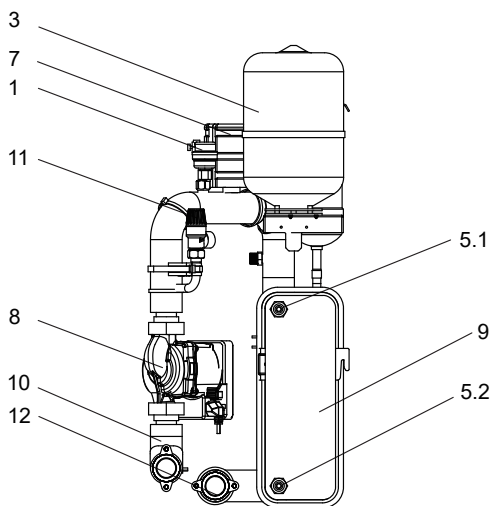

8 -16 kW unit without a backup heater

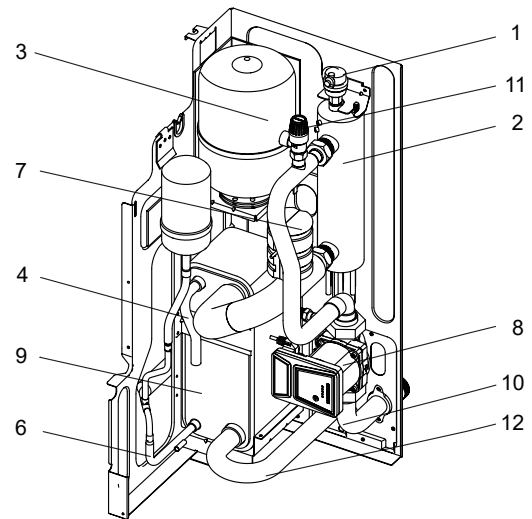

8 -16 kW unit with a backup heater (optional)

Code	Name	Explanation
1	Automatic air purge valve	Automatically removes the remaining air from the water loop.
2	Backup heater (optional)	Provides additional heating capacities when the heating capacity of the heat pump is insufficient due to low outdoor temperature, and protects the external water pipes from freezing.
3	Expansion vessel	Balances the water system's pressure.
4	Refrigerant gas pipe	/
5	Temperature sensor	Four temperature sensors determine the water and refrigerant temperature at various points in the water loop: 5.1-TW_out, and 5.2-TW_in
6	Refrigerant liquid pipe	/
7	Flow switch	Detects the water flow rate to protect the compressor and water pump in the event of insufficient water flow.
8	Pump	Circulates water in the water loop.
9	Plate heat exchanger	Transfers heat from the refrigerant to the water.
10	Water outlet pipe	/
11	Pressure relief valve	Prevents excessive water pressure by opening when the pressure reaches 0.3 MPa(3 bar) and discharging water from the water loop.
12	Water inlet pipe	/

3 SAFETY ZONE

The refrigerant circuit in the outdoor unit contains easily flammable refrigerant in safety group A3 as described in ISO 817 and ANSI/ASHRAE Standard 34. Therefore, a safety zone is defined in the immediate vicinity of the outdoor unit, in which special requirements apply. Note that this refrigerant has a higher density than air. In the event of a leak, escaping refrigerant may be collected near the earth.

The following conditions must be avoided within the safety zone:

- Building openings such as windows, doors, light wells, and flat roof windows;
- Outdoor air and exhaust air apertures of ventilation and air conditioning systems;
- Property boundaries, neighboring properties, footpaths, and driveways;
- Pump shafts, inlets to waste water systems, downpipes, and waste water shafts, etc.;
- Other slopes, troughs, depressions, and shafts;
- Electrical house supply connections;
- Electrical systems, sockets, lamps, and light switches; Snowfall from roofs.

Do not introduce ignition sources into the safety zone:

- Naked flames or burner gauze assemblies.
- Grills.
- Tools that generate sparks.
- Electrical devices not free of ignition sources, mobile devices with integrated batteries (such as mobile phones and fitness watches).
- Objects with a temperature of above 360 °C.

NOTE

The particular safety zone is dependent on the surroundings of the outdoor unit.

- The safety zones below are shown with floor standing installation. These safety zones also apply to other types of installation.

Freestanding positioning of the outdoor unit

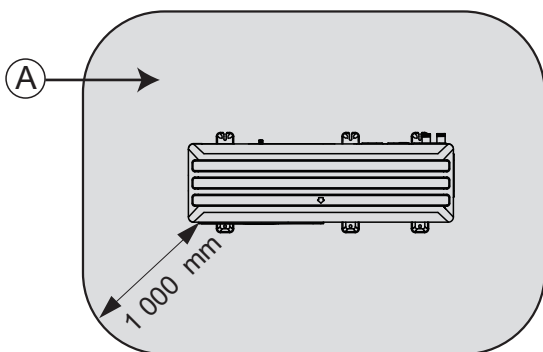

Safety zone

Siting the outdoor unit in front of an external wall

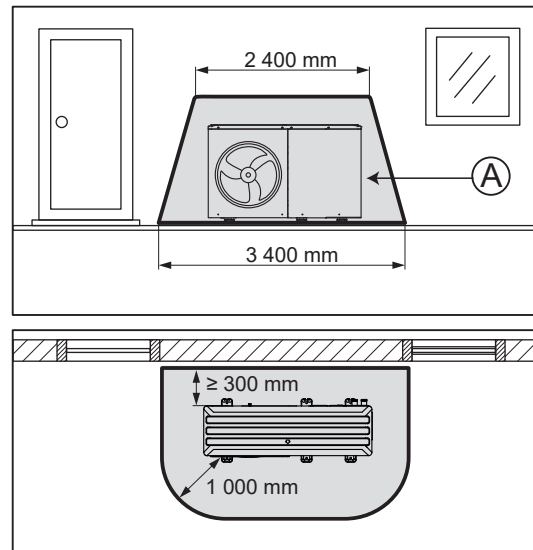

Safety zone

Corner positioning of the outdoor unit, left

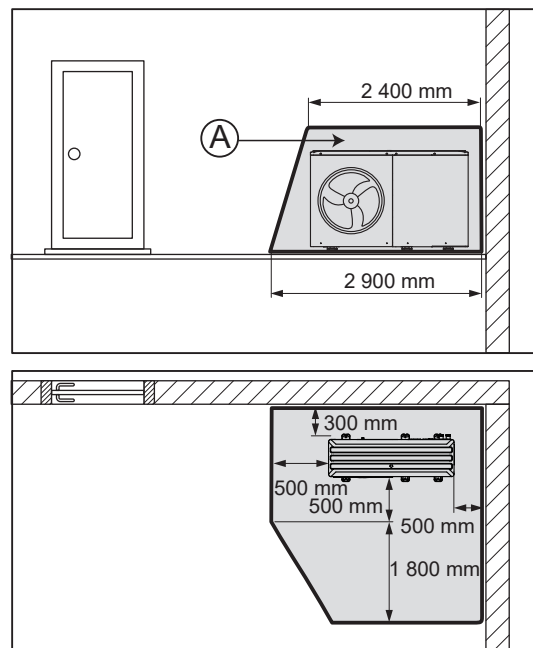

4 UNIT INSTALLATION

General

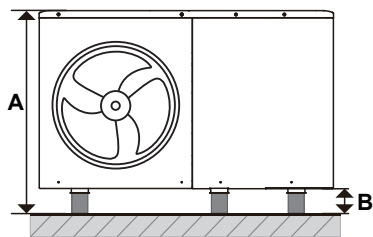

Obstacle over the top

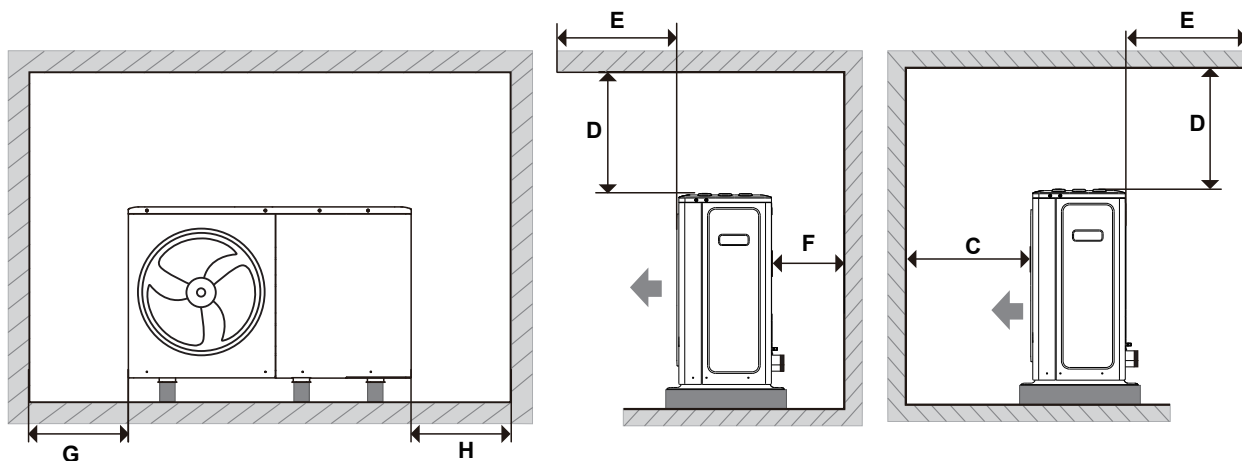

No obstacle over the top

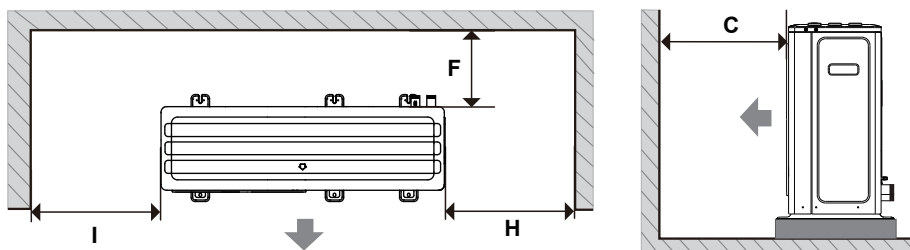

4-10 kW

(mm)

A	Unit height + B	D	≥ 500	G	≥ 500
B	≥ 100 *	E	≤ 500	H	≥ 500
C	≥ 1 000	F	≥ 300	I	≥ 500

12-16 kW

A	Unit height + B	D	≥ 500	G	≥ 500
B	≥ 100 *	E	≤ 500	H	≥ 500
C	≥ 1 500	F	≥ 300	I	≥ 500

* In case of cold weather, take into account of snow on the ground. For more information, refer to 4.4 In Cold Climates.

For cascade application installation clearance, refer to the INSTALLATION, OPERATION AND MAINTENANCE MANUAL.

4.1 Conditions for installation

The product can be installed on a ground or flat roof. Pitched-roof installation is not permitted. For installation on a flat roof, refer to the INSTALLATION, OPERATION AND MAINTENANCE MANUAL.

4.2 Foundation and unit installation (installation on a ground)

Installation on a soft ground

In case of installation on a soft ground (such as on a lawn or earthy ground), refer to the INSTALLATION, OPERATION AND MAINTENANCE MANUAL for the recommended preparations for the foundation.

Installation on a solid ground

In case of installation on a solid ground (such as on a concrete ground), refer to the INSTALLATION, OPERATION AND MAINTENANCE MANUAL for the recommended preparations for the foundation.

Unit mounting

Installation with foundation: Fix the unit with foundation bolts. (Six Φ 10 expansion bolts, nuts and washers are needed, supplied on the site). Screw the foundation bolts to a depth of 20 mm in the foundation. Installation without foundation: Install proper anti-vibration pads and level the unit.

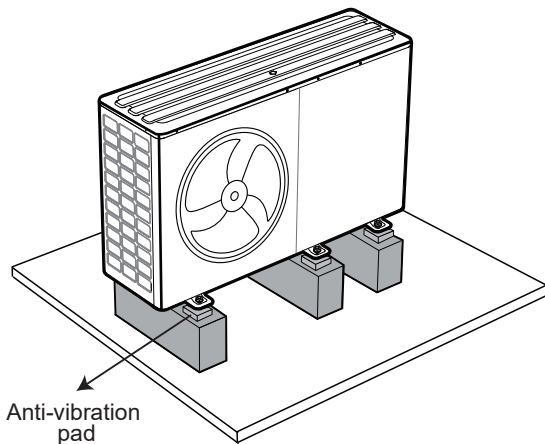

CAUTION

All six feet must be fixed.

Installation with foundation

4.3 Drainage

4.3.1 Drain hole position

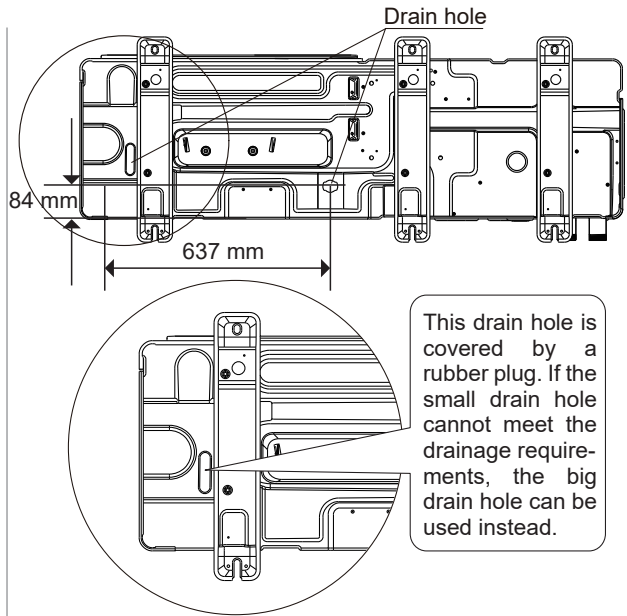
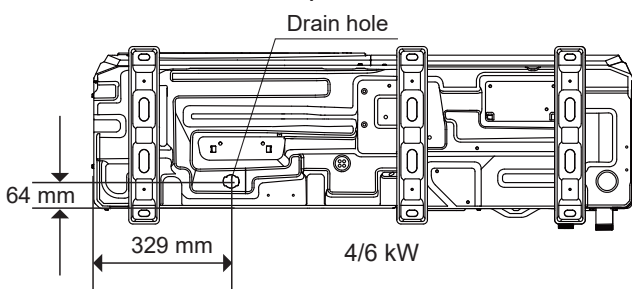

8/10/12/14/16 kW

CAUTION

- Watch the condensate when removing the rubber plug of the additional drain hole.
- Make sure the condensate is drained properly. Collect and direct the condensate that can drip from the base of the unit to a drain tray. Prevent water dripping onto the floor that may generate a slip hazard, especially in winter.
- For cold climate, it is highly recommended that a belt heater be installed to avoid damage to the unit due to the drain water freezing in case of a low drainage rate.

4.3.2 Drainage layout (installation on a ground)

Drain joint

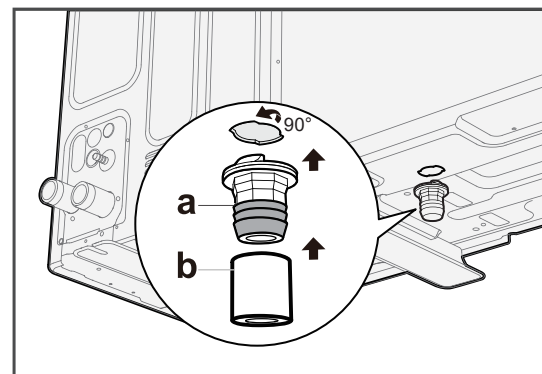

a – Drain joint (plastic, Pagoda connection, 1")

b - Drain hose (field supply)

Installation on a soft ground

Draining condensate into a gravel bed

For installation on a ground, the condensate must be discharged via a downpipe into a gravel bed that is located in a frost-free area.

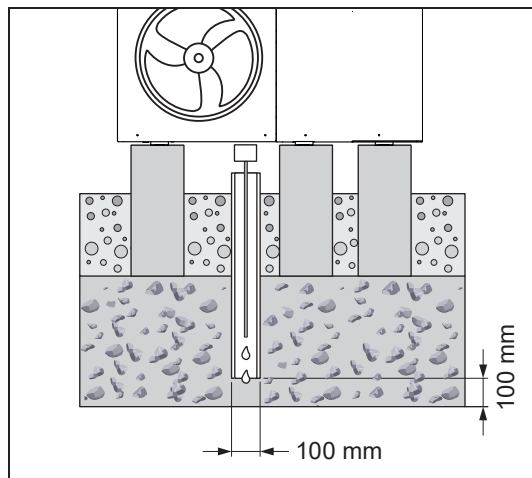

The downpipe must go into a sufficiently large gravel bed so that the condensate can trickle away freely. For more methods, refer to the INSTALLATION, OPERATION AND MAINTENANCE MANUAL.

NOTE

To prevent the condensate from freezing, self-regulating heating cable(field supply) must be threaded into the downpipe so that the condensate can discharge via the downpipe.

Installation on a solid ground

Guide the condensation pipe to a sewer, pump sump or soakaway.

NOTE

- For all installation types, ensure that any condensate that accumulates is discharged into a frost-free area.
- To prevent the condensate from freezing, self-regulating heating cable(field supply) can be threaded into the downpipe so that the condensate can discharge via the downpipe.

4.4 In cold climates

It is recommended that the unit be placed with the rear side against the wall.

Install a lateral canopy on top of the unit to prevent lateral snowfall in extreme weather conditions.

Install a high pedestal or wall mount the unit to keep a proper clearance (at least 100 mm) between the unit and snow.

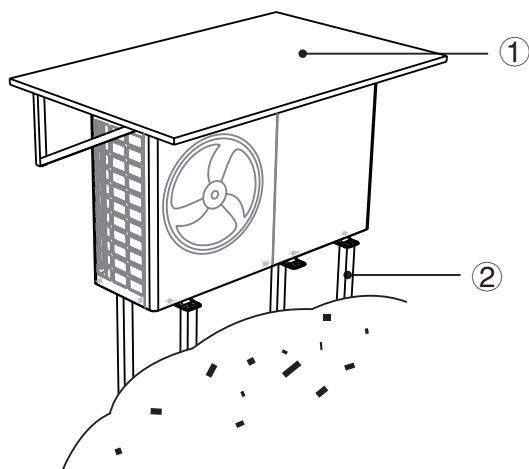

- ① Canopy or alike
- ② Pedestal in case of installation on a ground

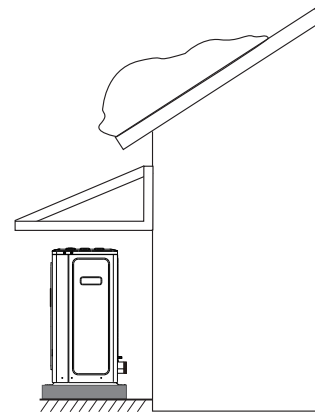

If there is a risk of snow slip from the roof, a protective roof or cover must be erected to protect the heat pump, pipes and wiring.

5 HYDRAULIC INSTALLATION

5.1 Preparations for installation

NOTE

- In case of plastic pipes, make sure they are fully oxygen-tight according to DIN 4726.
- The diffusion of oxygen into the piping can lead to excessive corrosion.

Minimum water volume

Check and ensure that the total water volume in the installation is at least 40 liters, excluding the internal water volume of the outdoor unit.

Flow rate range

The operation flow rate range of the unit is shown as below. Check and ensure that the flow rate in the installation is guaranteed in all conditions.

Unit	4 kW	6 kW	8 kW	10 kW	12 kW	14 kW	16 kW
Flow rate range (m ³ /h)	0.4*~0.9	0.4*~1.25	0.4*~1.65	0.4*~2.10	0.7*~2.50	0.7*~2.75	0.7*~3.00

* The minimum output of the Pump_I can be set on wired controller.

CAUTION

- The heat exchanger could be damaged by freezing water due to low water flow rate.

Refer to the INSTALLATION, OPERATION AND MAINTENANCE MANUAL for more information.

5.2 Water loop connection

CAUTION

- Incorrect direction of the water outlet and inlet can cause unit malfunction.
- Do not apply excessive force when connecting the pipes provided on the site, and make sure the pipes are aligned properly. Water pipe deformation can cause unit malfunction.

1) Connect the Y- type strainer to the water inlet of the unit, and seal the connection with thread sealant. (To provide access to the Y- type strainer for cleaning, an extension pipe can be connected between the strainer and the water inlet depending on the field conditions)

2) Connect the pipe provided on the site to the water outlet of the unit.

3) Connect the outlet of the safety valve with a hose with a suitable size and length, and guide the hose to the condensate drain, as shown in 4.3.2.

4-6 kW

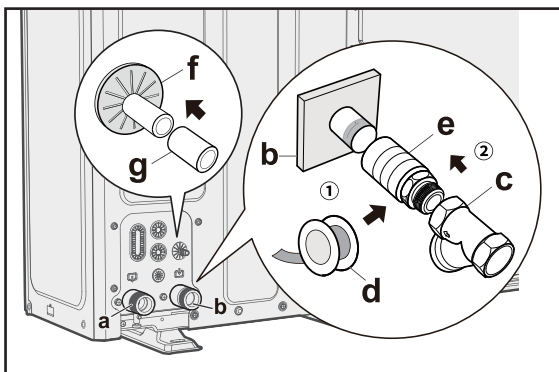

8-16 kW

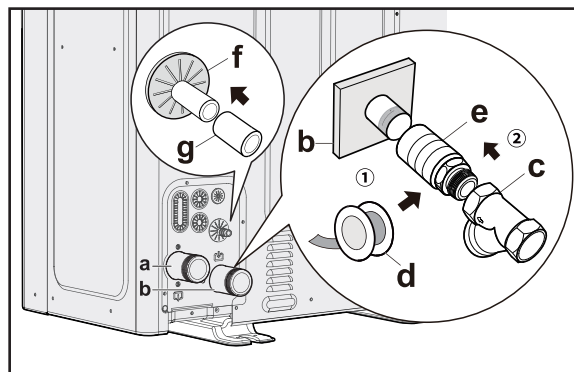

a	Water OUTLET (connection with screws, male, 1" for 4/6 kW units and 1 1/4" for 8-16 kW units)
b	Water INLET (connection with screws, male, 1" for 4/6 kW units and 1 1/4" for 8-16 kW units)
c	Y- type strainer (delivered with the unit) (2 screws for connection, female, 1" for 4/6 kW units and 1 1/4" for 8-16 kW units)
d	Thread seal tape
e	Extension pipe (recommended, with the length depending on the field conditions)
f	Safety valve outlet (hose, φ16 mm)
g	Drain hose (supplied on the site)

⚠ CAUTION

- The installation of the Y-type strainer at the water inlet is mandatory. To avoid metal particles damage the unit, It is recommended to install a magnetic filter before the Y-type strainer.
- Pay attention to the correct flow direction of the Y-type strainer.
- Sediment may damage the plate heat exchanger, and there could be refrigerant leakage risk without strainer.
- It is recommended to use strainer with 60 mesh or higher.

🔧 NOTE

Problems caused by not installing a filter are not covered by the warranty.

Domestic hot water

For the installation of the domestic hot water tank (supplied on the site), refer to the specific manual of the domestic hot water tank.

Others

🔧 NOTE

- Air vent valves must be installed at highest points of the system.
- Drain taps must be installed at lowest points of the system.

5.3 Filling water loop with water

🔧 NOTE

Before filling with water, please check 5.7 Water for the water quality requirements. Pumps and valves may become stuck as a result of poor water quality.

- Connect the water supply to the filling valve and open the valve. Follow applicable regulations.
- Make sure the automatic air vent valve is open.
- Ensure a water pressure of approximately 0.2 MPa(2 bar). Remove the air in the loop as much as possible using the air vent valves. Air in the water loop could lead to malfunction of the backup electric heater.

Do not fasten the black plastic cover on the vent valve at the top side of the unit when the system is running. Open the air vent valve, and turn it anticlockwise at least 2 full turns to release air from the system.

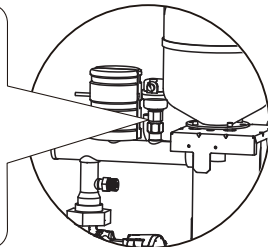

🔧 NOTE

The water pressure varies with the water temperature (higher pressure at higher water temperature). Always keep the water pressure above 0.03 MPa(0.3 bar) to prevent air from entering the loop.

Maximum water pressure	0.3 MPa(3 bar)
------------------------	----------------

5.4 Filling domestic hot water tank with water

See the specific manual of the domestic hot water tank.

5.5 Water pipe insulation

The complete water loop including all pipes, must be insulated to prevent condensation during cooling operation, heating and cooling capacity reduction, and freezing of the outside water pipes in winter.

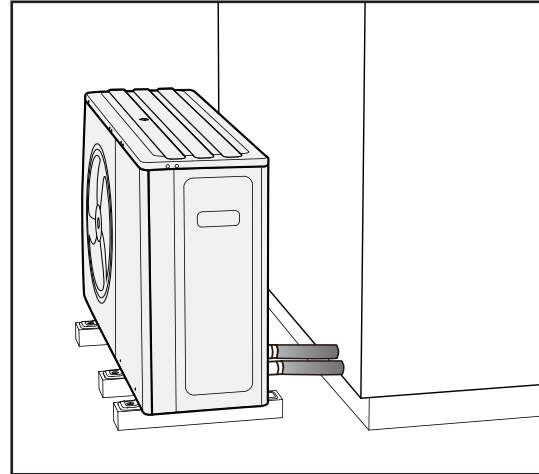

🔧 NOTE

- The insulation material should be provided with a fire resistance rating of B1 or above and comply with all applicable regulations.
- The thermal conductivity of the sealing material should be below 0.039 W/mK.

Recommended thickness of the sealing material is shown as below.

Piping length (m) between the unit and the terminal device	Minimum insulation thickness(mm)
< 20	19
20~30	32
30~40	40
40~50	50

5.6 Freeze protection

5.6.1 Protected by software

The software is equipped with specific functions to protect the entire system from freezing by using the heat pump and the backup heater (if available).

- When the temperature of the water flow in the system drops to a certain value, the unit will heat the water using the heat pump, electric heating tape, or backup heater.
- The anti-freeze function is enabled only when the temperature increases to a certain value.

CAUTION

- In the event of power failure, the above features would fail to protect the unit from freezing. Therefore, always keep the unit powered on.
- If the power supply for the unit is to be switched off for a long time, the water in the system pipe needs to be drained to avoid damage to the unit and pipeline system due to freezing.

5.6.2 Protected by glycol

Glycol lowers the freezing point of water.

CAUTION

Ethylene glycol and propylene glycol are toxic.

CAUTION

Glycol can corrode the system. When uninhibited glycol comes into contact with oxygen, it becomes acidic. This corrosion process is accelerated by copper and high temperature. The acidic uninhibited glycol attacks metal surfaces, forming galvanic corrosion cells that can cause severe damage to the system. Therefore, it is important to follow these steps:

- Let a qualified specialist treat the water correctly;
- Select a glycol with corrosion inhibitors to counteract acids formed by the oxidation of glycols;
- Do not use any automotive glycol because its corrosion inhibitors have a limited lifetime and contain silicates which can contaminate or block the system;
- Do not use galvanized pipes in glycol systems as such pipes may lead to the precipitation of certain components in the glycol's corrosion inhibitor.

NOTE

Glycol absorbs moisture from the environment, so it is important to avoid using glycol exposed to air. If glycol is left uncovered, the water content increases, lowering the glycol concentration and potentially causing hydraulic components to freeze. To prevent this, take precautions and minimize glycol's exposure to air.

Types of glycol

The types of glycol that can be used depend on whether the system contains a domestic hot water tank:

If	Then
The system contains a domestic hot water tank	Only use propylene glycol (a)
The system does NOT contain a domestic hot water tank	Either propylene glycol(a) or ethylene glycol can be used

(a) Propylene glycol, including the necessary inhibitors, falls in Category III according to EN1717.

Required concentration of glycol

The required concentration of glycol depends on the lowest expected outdoor temperature, and on whether you want to protect the system from bursting or from freezing. To prevent the system from freezing, more glycol is required.

Add glycol according to the table below.

Lowest expected outdoor temperature	Prevention [1] from bursting	Prevention [2] from freezing
-5 °C	10 %	15 %
-10 °C	15 %	25 %
-15 °C	20 %	35 %
-20 °C	25 %	N/A
-25 °C	30 %	N/A
-30 °C	35 %	N/A

- [1] : Glycol can prevent the piping from bursting, but cannot prevent the liquid inside the piping from freezing.
- [2] : Glycol can prevent the liquid inside the piping from freezing.

NOTE

- The required concentration might vary depending on the type of glycol used. ALWAYS compare the requirements from the table above with the specifications provided by the glycol manufacturer. If necessary, meet the requirements set by the glycol manufacturer.
 - The added concentration of glycol should NEVER exceed 35 %.
 - If the liquid in the system is frozen, the pump will NOT be able to start. Please note that solely preventing the system from bursting may not prevent the liquid inside from freezing.
 - If water remains stagnant within the system, it is highly likely to freeze and result in system damage.

NOTE

Adding glycol to the water loop reduces the maximum allowed water volume of the system. See the INSTALLATION, OPERATION AND MAINTENANCE MANUAL for more information.

5.7 Water

NOTE

- Circulators function well exclusively with clean and high-quality tap water.
- Risk of material damage due to poor-quality water.
- The most frequent factors that can affect circulators and the system are oxygen, limescale, sludge, acidity level and other substances (including chlorides and minerals).
- In addition to the quality of water, installation also plays an important role. The heating system must be airtight. Choose materials that are not sensitive to oxygen diffusion (risk of corrosion...).

Characteristics of the water

- Compliant with local regulations.
- Langelier Index (LI) between 0 and + 0.4.
- Within the limits indicated in the chart.

Water quality must be checked by qualified personnel.

Hardness

If the water is hard, install a system suitable to preserve the unit from harmful deposits and limestone formation.

NOTE

If necessary, fit a water softener to reduce water hardness.

Cleanliness

Before connecting the water to the unit, clean the system thoroughly with specific products effective to remove residues or impurities that may affect functioning. Existing systems must be free from sludge and contaminants and protected against buildups.

New systems

In case of new installations, it is essential to wash the entire installation (with the circulator uninstalled) before commissioning the central installation. This removes residues of the installation process (welding, waste, joint products...) and preservatives (including mineral oil). The system must then be filled with clean high-quality tap water.

Existing systems

If a new boiler or heat pump is installed on an existing heating system, the system must be rinsed to avoid the presence of particles, sludge and waste. The system must be drained before installing the new unit. Dirt can be removed only with a suitable water flow. Each section must then be washed separately.

Particular attention must also be paid to "blind spots" where a lot of dirt can accumulate due to the reduced water flow. The system must then be filled with clean high-quality tap water. If, after rinsing, the quality of the water is still unsuitable, a few measures must be taken to avoid problems. An option to remove pollutants is to install a strainer. Various types of strainers are available. A mesh strainer is designed to catch large dirt particles. This strainer is usually placed in the part with the larger flow. A tissue strainer is designed to catch the finer particles.

Water component for corrosion limit on copper

PH	7.5-9.0	
Ryznar Stability Index (RSI)	< 6.0	
Electric conductivity	100-500	µS/cm
Total Hardness	4.5-8.5	dH
Max. quantity glycol	40	%
Sulfate ions (SO ₄)	< 50	ppm
Alkalinity (HCO ₃)	70-300	ppm
Chloride ions (Cl ⁻)	< 50	ppm
Phosphates (PO ₄)	< 2.0	ppm
NH ₃	< 0.5	ppm
Iron (Fe)	< 0.3	ppm
Manganese (Mn)	< 0.05	ppm
Sulfur (S)	None	
Ammonium ions (NH ₄)	None	
Silica (SiO ₂)	< 30	ppm
CO ₂	< 50	ppm
Oxygen content	< 0.1	ppm
Sand	< 10 mg/L, 0.1 to 0.7mm max diameter	
Ferrite hydroxide Fe ₃ O ₄ (black)	Dose < 7.5 mg/L, 50 % of mass, with diameter < 10 µm	
Iron oxide Fe ₂ O ₃ (red)	Dose < 7.5 mg/L, diameter < 1 µm	

CAUTION

If a potable water source is used as the equipment's water supply, a backsiphonage prevention device should be installed between the potable water source and the equipment.

6 ELECTRICAL INSTALLATION

⚠ DANGER

Risk of electrocution.

⚠ WARNING

- The appliance should be installed in accordance with national wiring regulations.
- Follow WIRING DIAGRAM for electrical wiring that is located on the rear side of the electrical box cover.
- This appliance incorporates an earth connection for functional purposes only.
- Be sure to install the required fuses or circuit breakers. An all-pole disconnection switch having a contact separation of at least 3 mm in all poles should be connected in fixed wiring.

⚠ WARNING

It is prohibited to install emergency stop switches, remote switches which for stopping the unit, including circuit breaker, contactor and relay, within 2 meters of the unit.

Refer to the INSTALLATION, OPERATION AND MAINTENANCE MANUAL for more practical instructions.

6.1 Opening the electrical box cover

To access the unit for installation and maintenance, follow the instructions below.

⚠ WARNING

Risk of electrocution.
Risk of burning.

🔧 NOTE

- Illustrations below are based on 8-16 kW units. The principle is the same for 4-6 kW units.
- Keep the screws properly for later use.

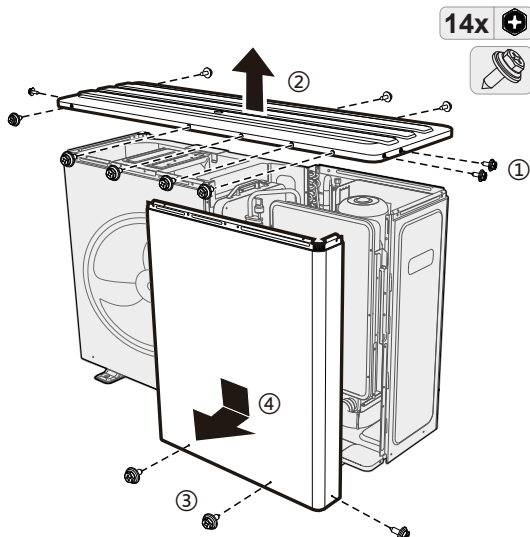

6x

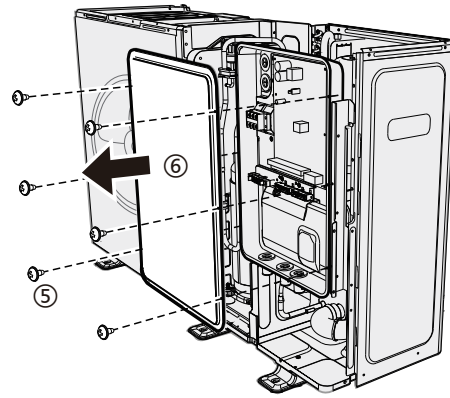

6.2 Back plate layout for wiring

4-6 kW

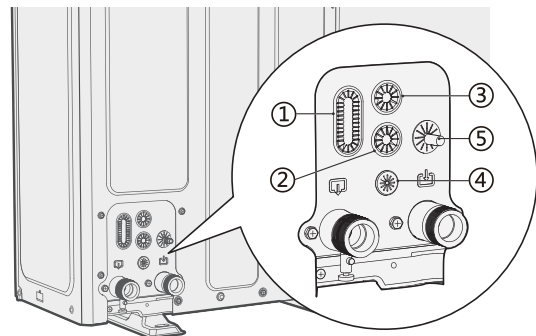

8-16 kW

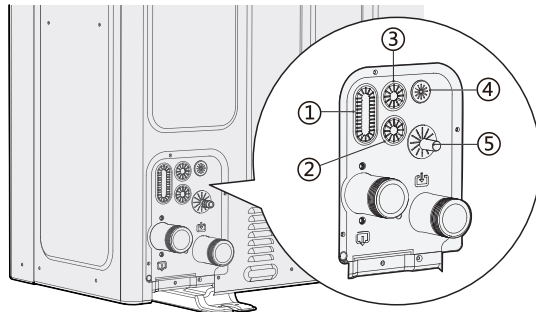

① ② ③	For high voltage wiring.
④	For low voltage wiring.
⑤	Safety valve drain.

6.3 Electrical wiring

Operating current and wire diameter

Refer to the INSTALLATION, OPERATION AND MAINTENANCE MANUAL for more information.

Tightening torques

Item	Tightening torque (N·m)
M4 (power terminal, electric control board terminal)	1.2 to 1.4
M4 (earthed)	1.2 to 1.4

6.4 Connection of power supply

6.4.1 Wiring of main power supply

⚠ CAUTION

- Use a round crimp-style terminal for connection to the power supply terminal board. If it is not available, refer to the INSTALLATION, OPERATION AND MAINTENANCE MANUAL for more information.
- The power cord model is or H07RN-F.
- Illustrations below are for 3-phase units. The principle is the same for 1-phase units.
- Illustrations below are for units with a backup heater. For more illustrations, refer to the INSTALLATION, OPERATION AND MAINTENANCE MANUAL.

Unit	Power supply	Maximum circuit current (A)	Minimum wire size (mm ²)
4 kW	220-240 V~ 50 Hz	15	(2 + PE) x (2.5-4)
6 kW		15	(2 + PE) x (2.5-4)
8 kW		19	(2 + PE) x (4-6)
10 kW		19	(2 + PE) x (4-6)
12 kW		31	(2 + PE) x (6-10)
14 kW		31	(2 + PE) x (6-10)
16 kW	31	(2 + PE) x (6-10)	
12 kW 3 PH	380-415 V 3N~ 50 Hz	11	(4 + PE) x (2.5-4)
14 kW 3 PH		11	(4 + PE) x (2.5-4)
16 kW 3 PH		11	(4 + PE) x (2.5-4)

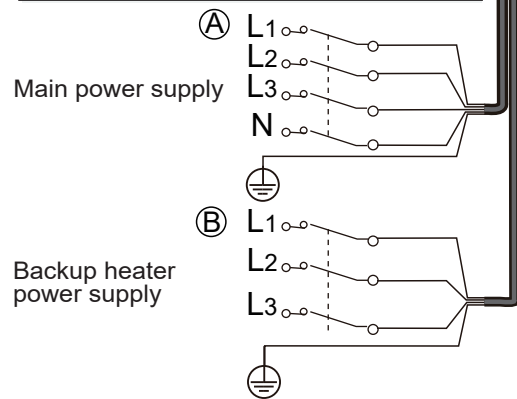
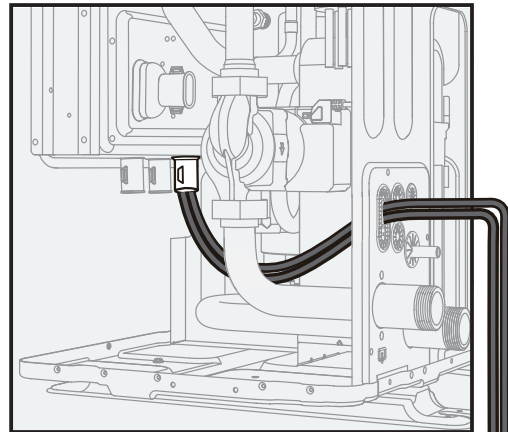
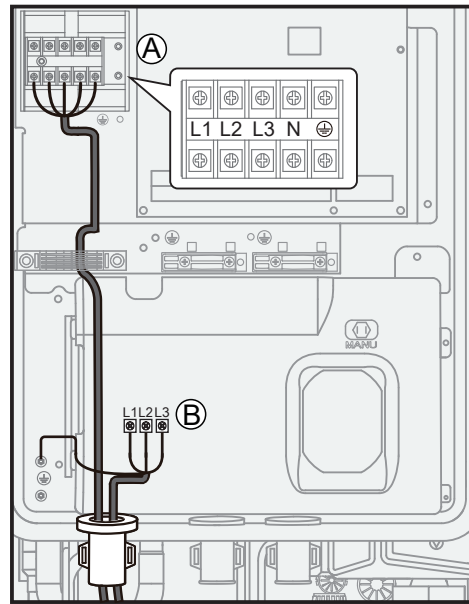

⚠ CAUTION

Leakage protection switch must be installed.

6.4.2 Wiring of backup heater power supply (optional)

Backup heater type	Power supply	Maximum circuit current (A)	Minimum wire size (mm ²)
3 kW	220-240 V~ 50 Hz	13.5	(2 + PE) x (2.5-4)
6 kW	380-415 V 3~ 50 Hz	13.5	(3 + PE) x (2.5-4)
9 kW	380-415 V 3~ 50 Hz	13.5	(3 + PE) x (2.5-4)

Refer to the illustration above for the wiring.

CAUTION

- To ensure the unit is fully earthed, always connect the backup heater power supply and the earth cable.
- This appliance which connect 1-phase 3 kW backup heater can be connected only to a supply with system impedance no more than 0.465 Ω. In case necessary, please consult your supply authority for system impedance information.

6.5 Connection of other components

The port provides the control signal to the load. Two kinds of control signal ports:

- Type 1: dry contactor without voltage.
- Type 2: the port provides the signal with 220-240 V~ 50 Hz voltage.

NOTE

- If the current of load is lower than 0.2 A, the load can be connected to the port directly. If the load current is higher than or equal to 0.2 A, it is necessary to connect the AC contactor to the load.
- Illustrations below are for 3-phase units. The principle is the same for 1 -phase units.
- Illustrations below are based on units with a backup heater.

6.5.1 Wiring of additional heating source control (AHS)

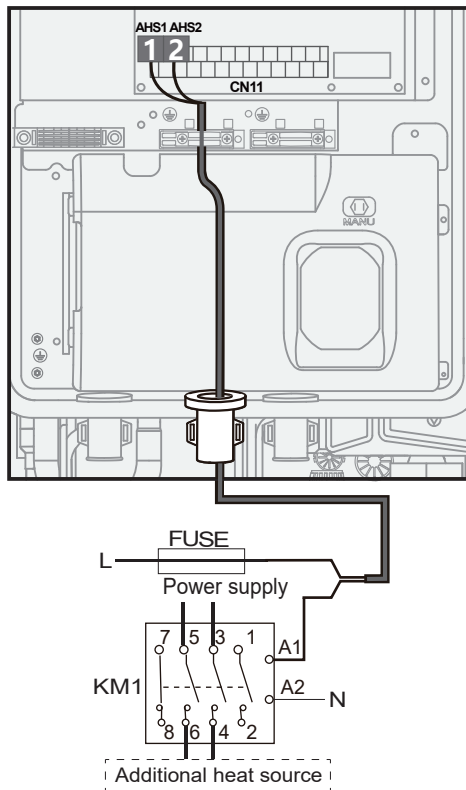

The wiring between the switch box and the back plate is shown in 6.4.1 Wiring of main power supply.

L-N Voltage	220-240 V AC
Maximum running current (A)	0.2
Minimum wire size (mm ²)	0.75
Control port signal type	Type 1

NOTE

This part only applies to basic units (without a backup heater). For customized units (with a backup heater), the hydraulic module should not be connected to any additional heat source as there is an interval backup heater in the unit.

6.5.2 Wiring of 3-way valves SV1, SV2 and SV3

NOTE

Refer to the INSTALLATION, OPERATION AND MAINTENANCE MANUAL for the installation locations of SV1, SV2 and SV3.

The illustration below is for this type of SV:

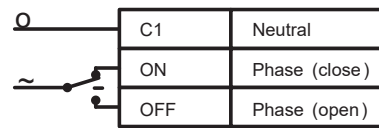

SV1:

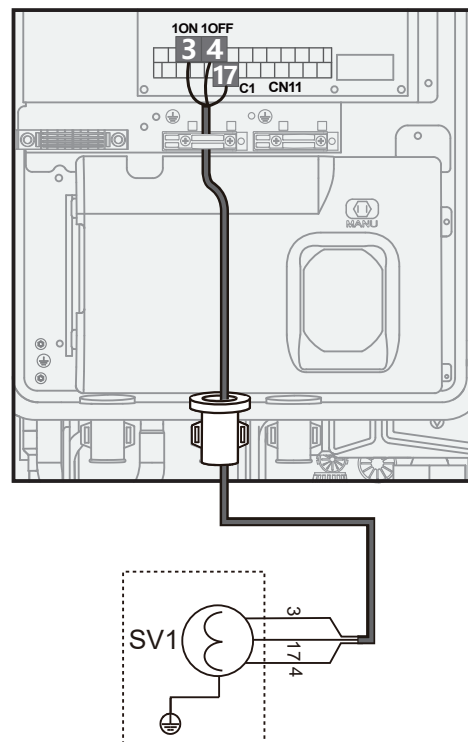

SV2:

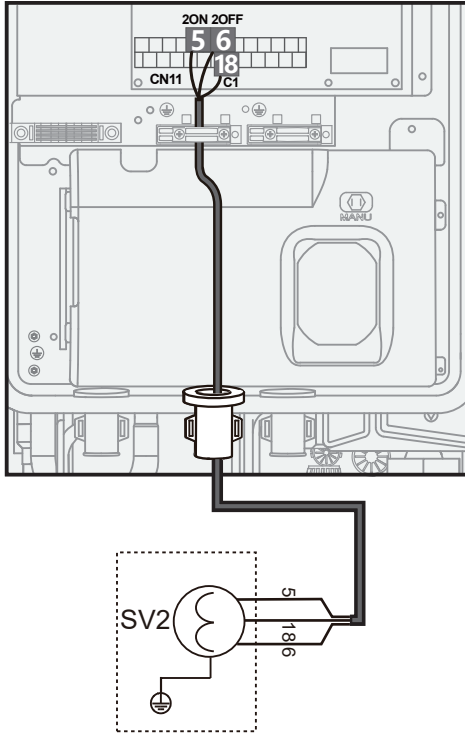

SV1:

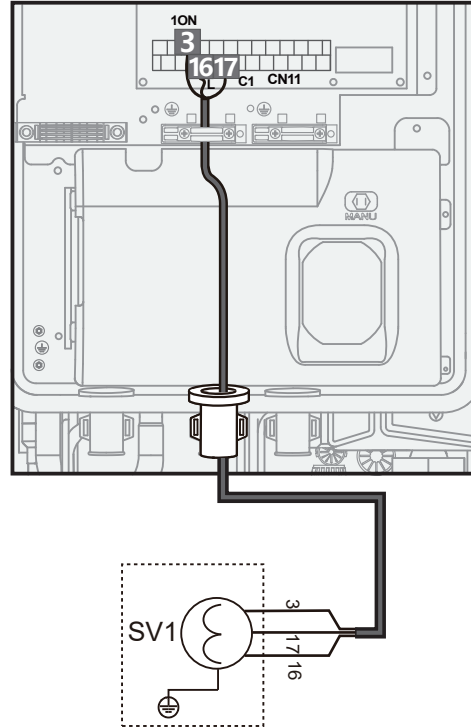

SV3:

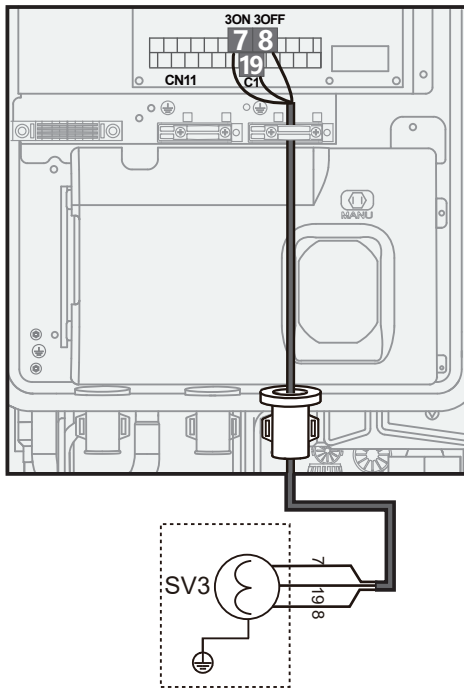

SV2:

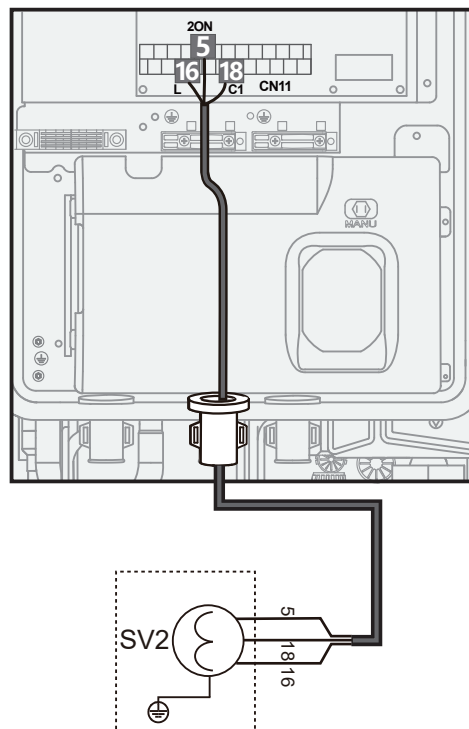

The illustration below is for this type of SV:

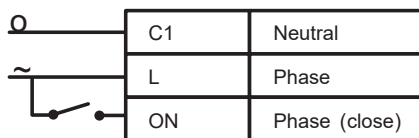

SV3:

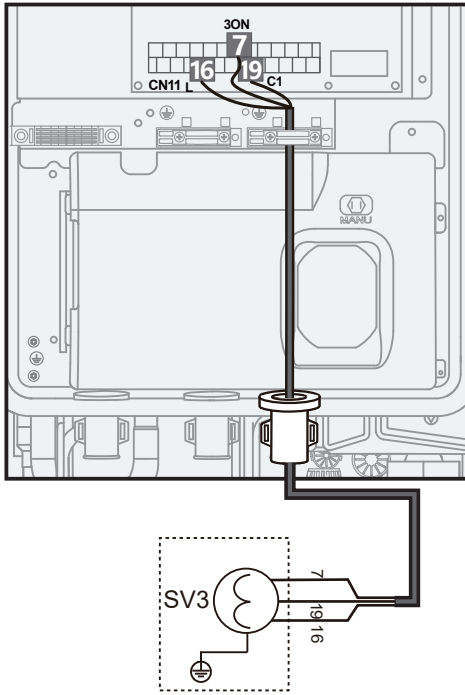

NOTE

C1 is for the neutral conductor .

Voltage	220-240 V AC
Maximum running current (A)	0.2
Minimum wire size (mm ²)	0.75
Control port signal type	Type 2

6.5.3 Wiring of additional pumps

Zone 2 pump P_c:

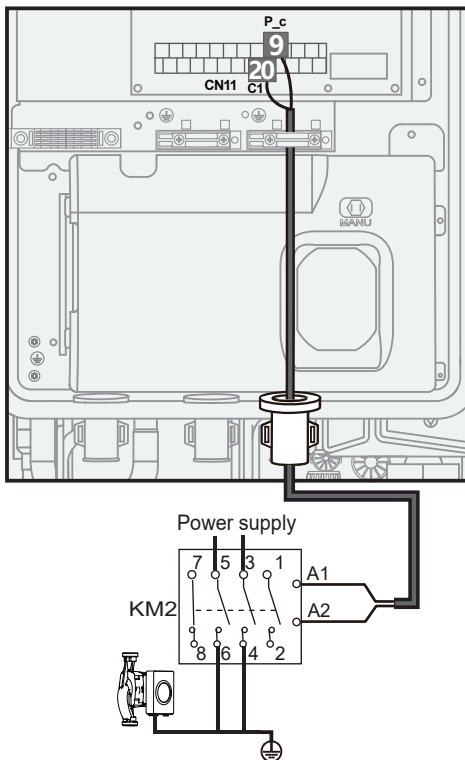

Additional circulation pump P_o:

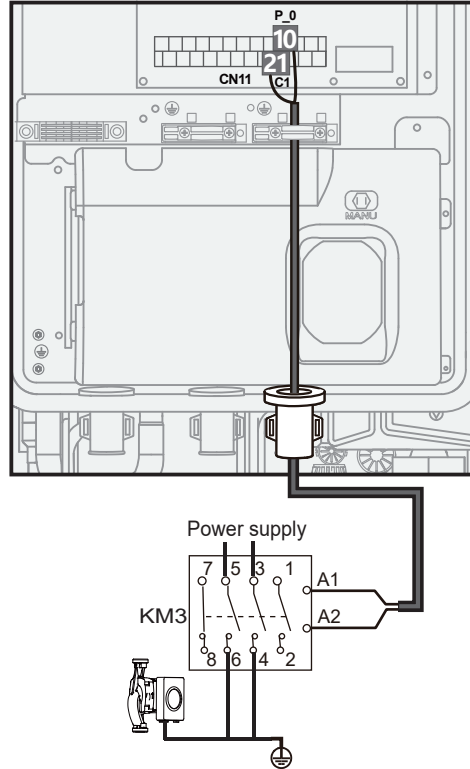

Solar energy pump P_s:

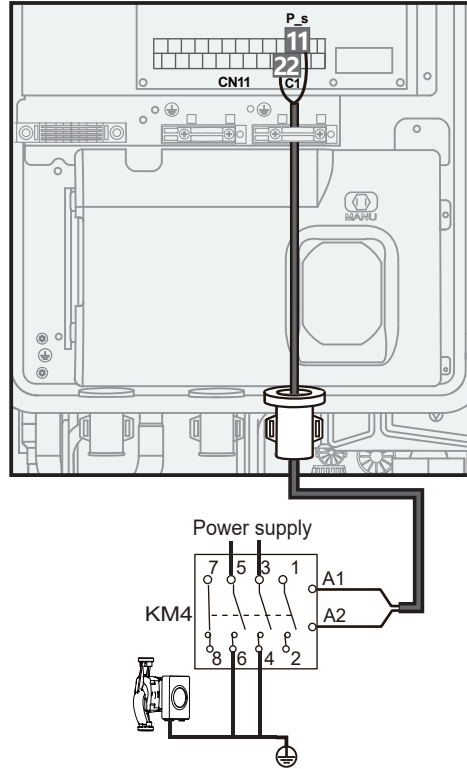

DHW pump P_d:

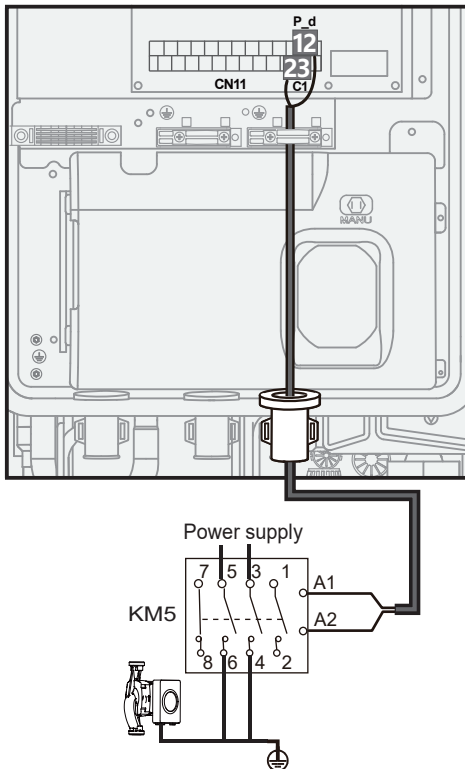

Voltage	220-240 V AC
Maximum running current (A)	0.2
Minimum wire size (mm ²)	0.75
Control port signal type	Type 2

6.5.4 Wiring of alarm or defrost run (P_x)

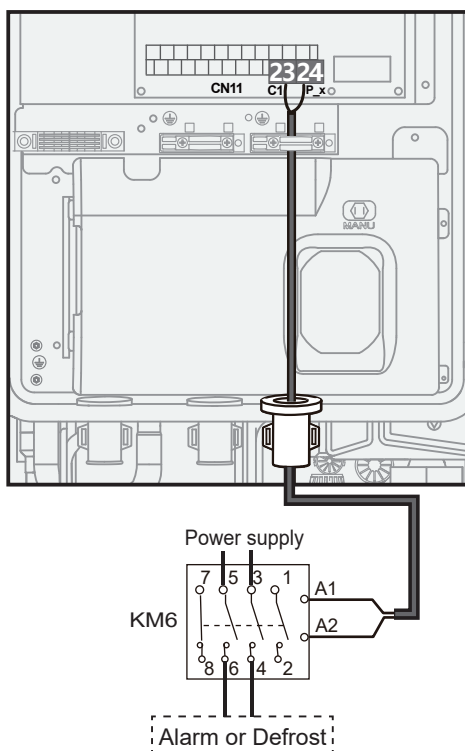

Voltage	220-240 V AC
Maximum running current (A)	0.2
Minimum wire size (mm ²)	0.75
Control port signal type	Type 2

6.5.5 Wiring of tank booster heater (TBH)

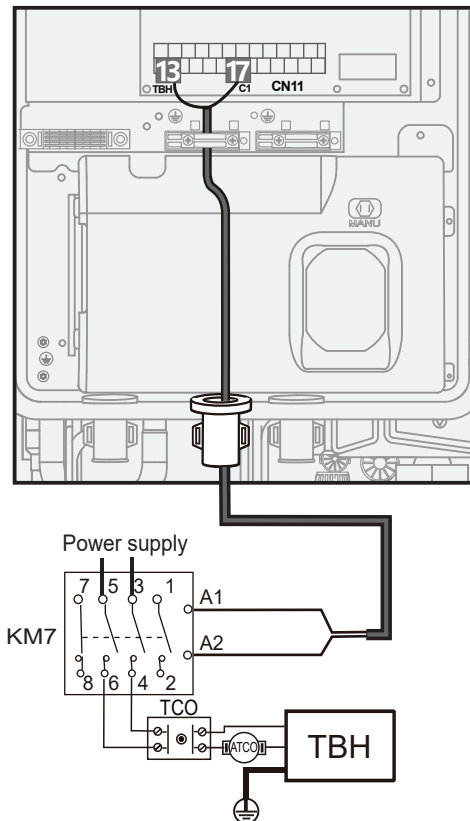

NOTE

TCO: Manual reset thermal protector.
ATCO: Auto reset thermal protector.

6.5.6 Wiring of external IBH box

NOTE

This is optional part, for more information, see the INSTALLATION, OPERATION AND MAINTENANCE MANUAL and installation manual of external IBH box.

If the DIP switch corresponding to the backup heater is set to INTERNAL (refer to the Wiring Diagram), C3 or C4 fault would appear after backup heater running.

For one-step control IBH:

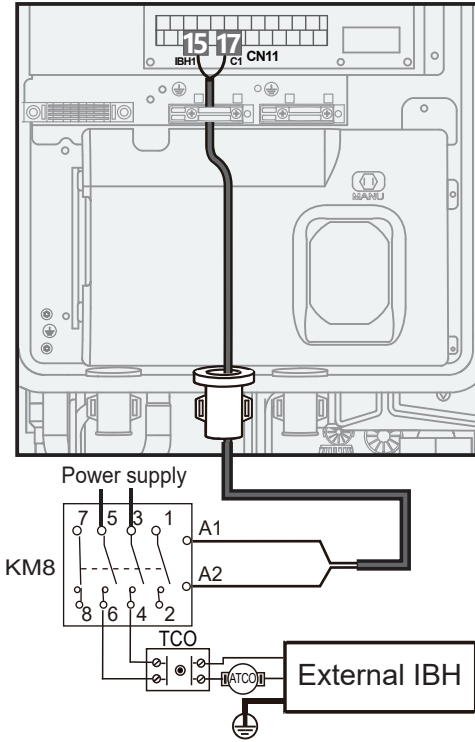

For two/three - step control IBH:

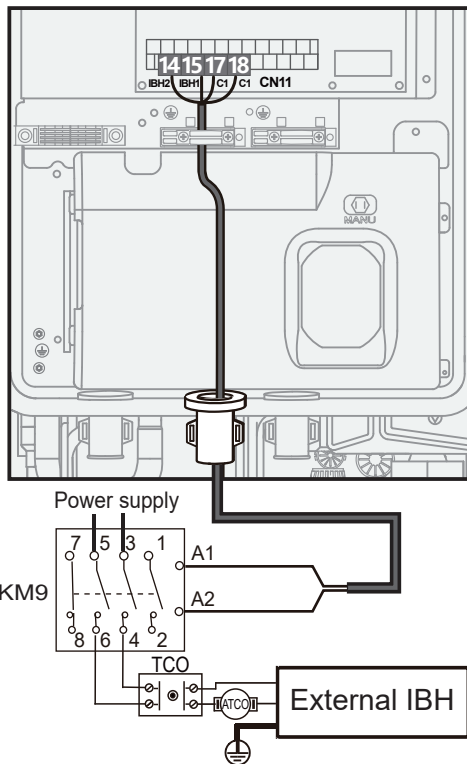

Voltage	220-240 V AC
Maximum running current (A)	0.2
Minimum wire size (mm ²)	0.75
Control port signal type	Type 2

NOTE

- The unit only sends an ON/OFF signal to the heater.
- IBH2 cannot be wired independently.

6.5.7 Wiring of room thermostat (RT)

Room thermostat (low voltage): "Power supply" provides the voltage to the RT.

NOTE

The room thermostat must be low-voltage.

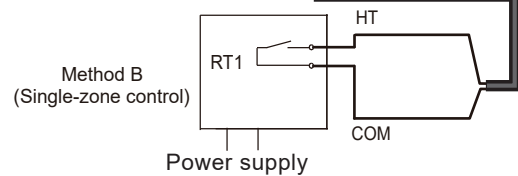
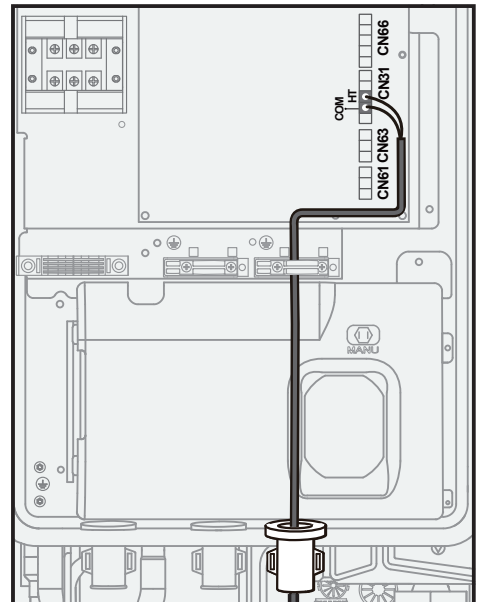
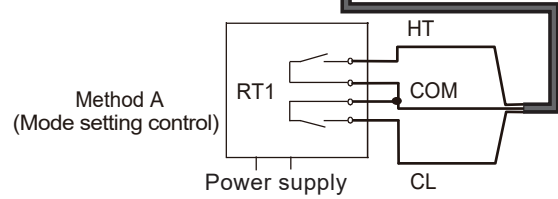
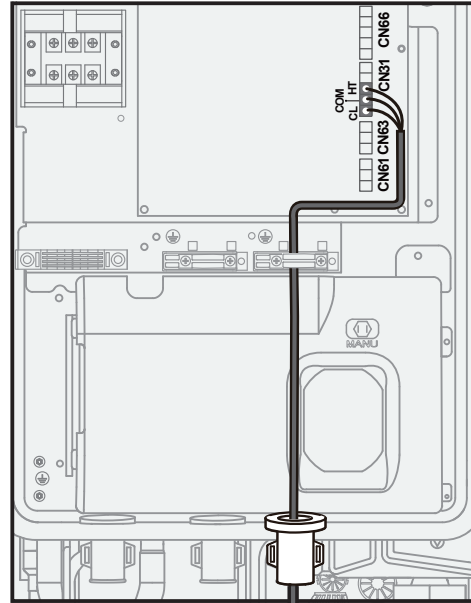

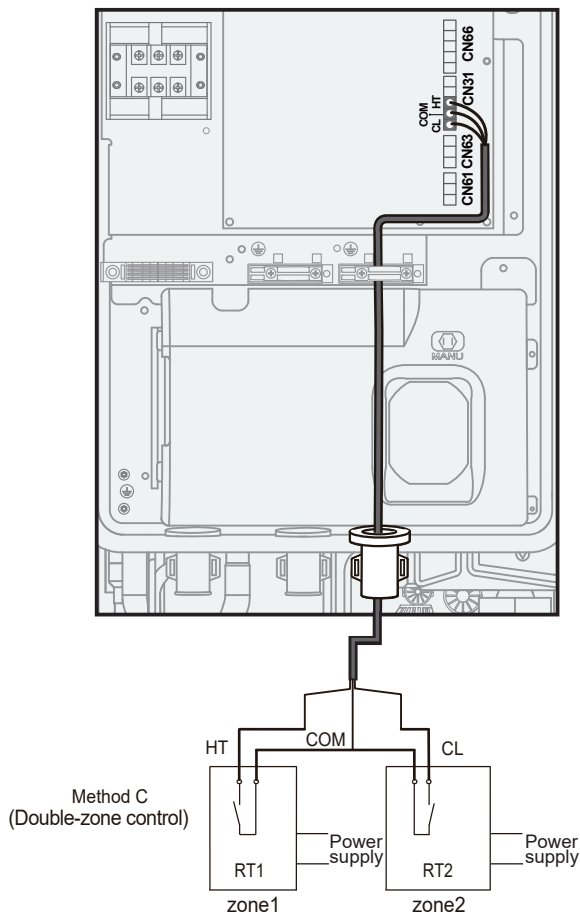

The thermostat cable can be connected in three ways (as described in the figures above) and the specific connection method depends on the application.

Method A (Mode set control)

RT can control heating and cooling individually. When the hydraulic module is connected with the external temperature controller, ROOM THERMOSTAT is set to MODE SET on the user interface:

A.1 When “CL” of the thermostat keeps closing for 15 s, the system will run according to the priority mode set on the user interface. The default priority mode is Heating.

A.2 When “CL” of the thermostat keeps opening for 15 s and “HT” close, the system will run according to the non-priority mode set on the user interface.

A.3 When “HT” of the thermostat keeps opening for 15 s and “CL” open, the system will turn off. (Mode set control)

A.4 When “CL” of the thermostat keeps opening for 15 s and “HT” open, the system will turn off.

The port closing voltage is 12 V DC, the port disconnection voltage is 0 V DC.

Method B (single-zone control)

RT provides the switch signal to the unit. ROOM THERMOSTAT is set to ONE ZONE on the user interface:

B.1 When “HT” of the thermostat keeps closing for 15 s, unit turns on.

B.2 When “HT” of the thermostat keeps opening for 15 s, unit turns off.

Method C (double-zone control)

The hydraulic module is connected with two room thermostats, and ROOM THERMOSTAT is set to DOUBLE ZONE on the user interface:

C.1 When “HT” of the thermostat keeps closing for 15 s, zone1 turn on. When “HT” of the thermostat keeps opening for 15 s, zone1 turn off.

C.2 When “CL” of the thermostat keeps closing for 15 s, zone2 turn on. When “CL” of the thermostat keeps opening for 15 s, zone2 turn off.

NOTE

- The wiring of the thermostat should correspond to the settings of the wired controller. Refer to 9.2 Configuration.
- Power supply of the device and room thermostat must be connected to the same neutral line.
- When ROOM THERMOSTAT is not set to NON, the indoor temperature sensor Ta cannot be set to VALID.
- Zone 2 can only operate in heating mode. When cooling mode is set on the wired controller and zone 1 is OFF, “CL” in Zone 2 closes, and system still remains 'OFF'. For installation, the wiring of thermostats for Zone 1 and Zone 2 must be correct.

6.5.8 Wiring of solar energy input signal (low voltage)

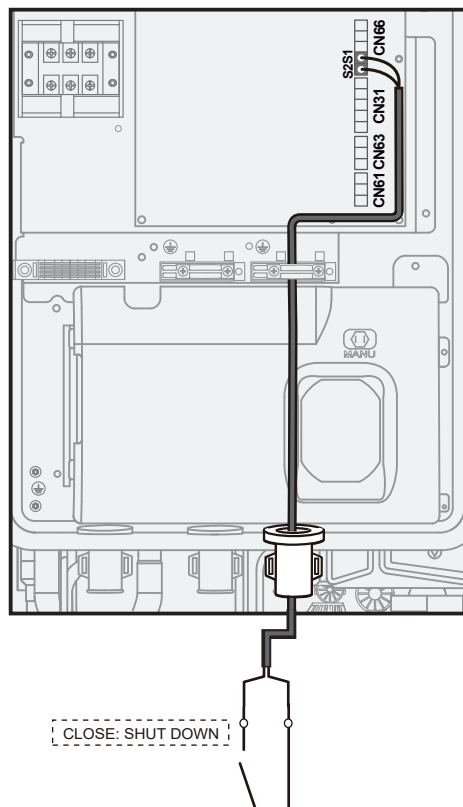

6.5.9 Wiring of remote shutdown

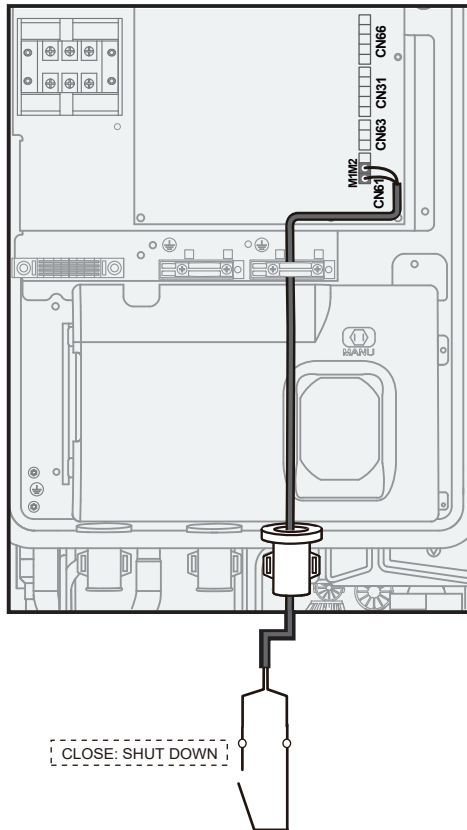

6.5.10 Wiring of smart grid

The unit has a smart grid feature, and there are two ports on the PCB to connect SG signals and EVU signals as below:

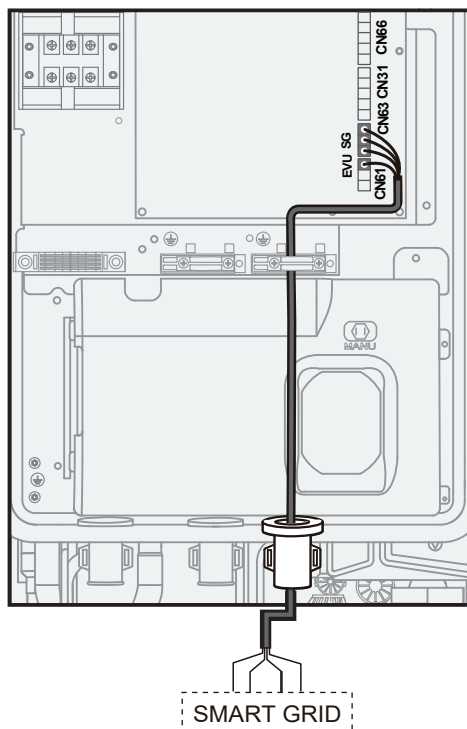

NOTE

To utilize smart grid function, the DHW mode must be set available.

1) SG = ON, EVU = ON.

- The heat pump will operate in DHW mode firstly.
- When TBH is set available, if T5 is lower than 69 °C, the TBH will be turned on forcibly (The heat pump and TBH can operate at the same time.); if T5 is higher than or equal to 70 °C, the TBH will be turned off. (DHW: Domestic Hot Water; T5S is the set temperature of the water tank.)

- When TBH is set unavailable and IBH is set available for DHW mode, if T5 is lower than 69 °C, the IBH will be turned on forcibly (The heat pump and IBH can operate at the same time.); if T5 is higher than or equal to 70 °C, the IBH will be turned off.

2) SG = OFF, EVU = ON.

- The heat pump will operate in DHW mode firstly.
- When TBH is set available and DHW mode is set ON, if T5 is lower than T5S-2, the TBH will be turned on (The heat pump and TBH can operate at the same time.); If T5 is higher than or equal to T5S + 3, the TBH will be turned off.

- When TBH is set unavailable and IBH is set available for DHW mode, if T5 is lower than T5S-dT5_ON, the IBH will be turned on (The heat pump and IBH can operate at the same time.); If T5 is higher than or equal to Min (T5S + 3,70), the IBH will be turned off.

3) SG = OFF, EVU = OFF.

The unit will operate properly.

4) SG = ON, EVU = OFF.

The heat pump, IBH, and TBH will be turned off immediately.

6.6 Cascade function

See the INSTALLATION, OPERATION AND MAINTENANCE MANUAL.

6.7 Connection of other optional components

See the INSTALLATION, OPERATION AND MAINTENANCE MANUAL.

The layout of the drainage pipe heating tape shows as below. For the heating tape selection, you can refer to the output of the connector in the WIRING DIAGRAM.

Bottom plate heating tape

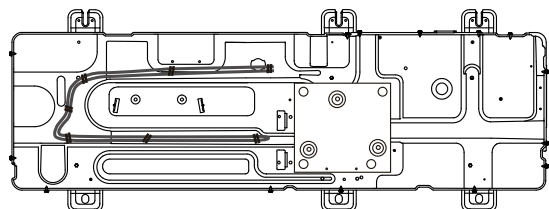

WARNING

Use tie wraps

To prevent refrigerant or insects from entering into the electrical control box and causing fire,

after wiring, the sleeve



should be

fastened with a tie wrap (accessory)



7 INSTALLATION OF WIRED CONTROLLER

⚠ CAUTION

- The general instructions on wiring in previous chapters should be observed.
- The wired controller must be installed indoors and kept away from direct sunlight.
- Keep the wired controller away from any ignition source, flammable gas, oil, water vapor, and sulfide gas.
- To avoid electromagnetic disturbance, keep the wired controller at a proper distance from electric appliances, such as lamps.
 - The circuit of the remote wired controller is a low-voltage circuit. Never connect it with a standard 220-240 V~/380-415 V~ circuit or place it into a same wiring tube with the circuit.
- Use a terminal connection block to extend the signal wire if necessary.
- Do not use a megger to check insulation of the signal wire upon completion of connection.

7.1 Materials for installation

Verify that the accessory bag contains the following items:

No.	Name	Qty.	Remarks
1	Wired controller	1	_____
2	Wood screw ST 4 × 20	4	For mounting on a wall
3	Plastic support bar	2	For mounting on an 86-type box
4	Philips head screw, M 4 × 25	2	For mounting on an 86-type box
5	Wall plugs	4	For mounting on a wall
6	Bottom cap of the wired controller	1	_____

7.2 Dimensions

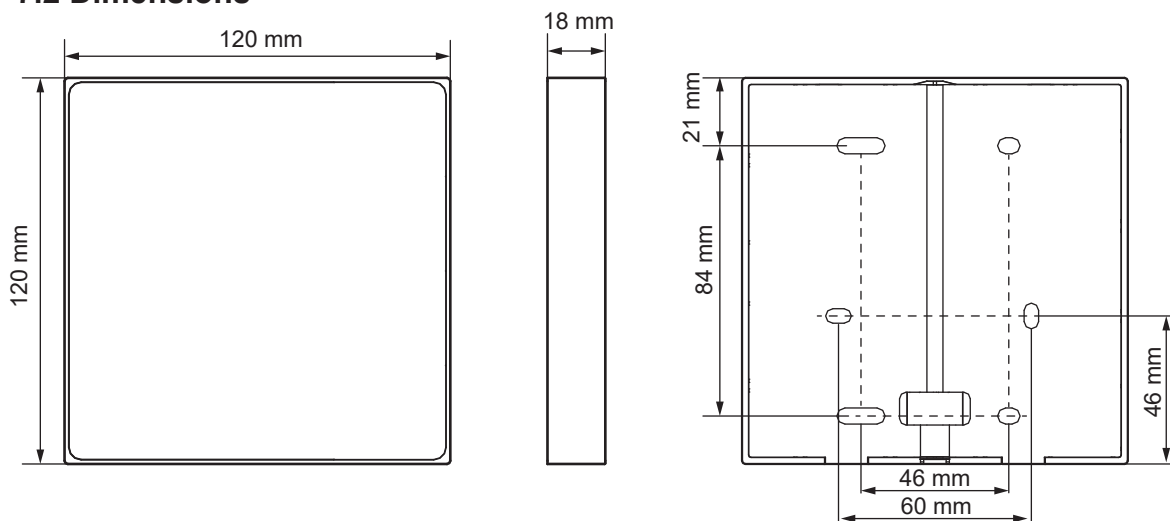

7.3 Wiring

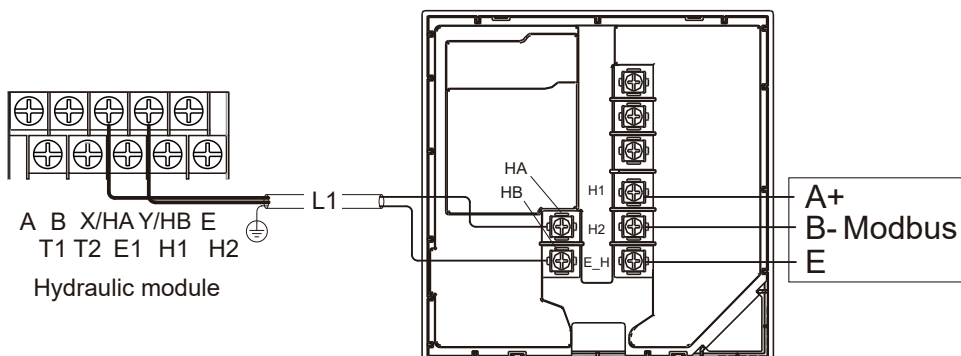

Input voltage (HA/HB)	18 V DC
Wire size	0.75 mm ²
Wire type	2-core shielded twisted pair cable
Wire length	L1 ≤ 50 m

The maximum length of the communication wire between the unit and the controller is 50 m.

Route

Bottom-side wiring out

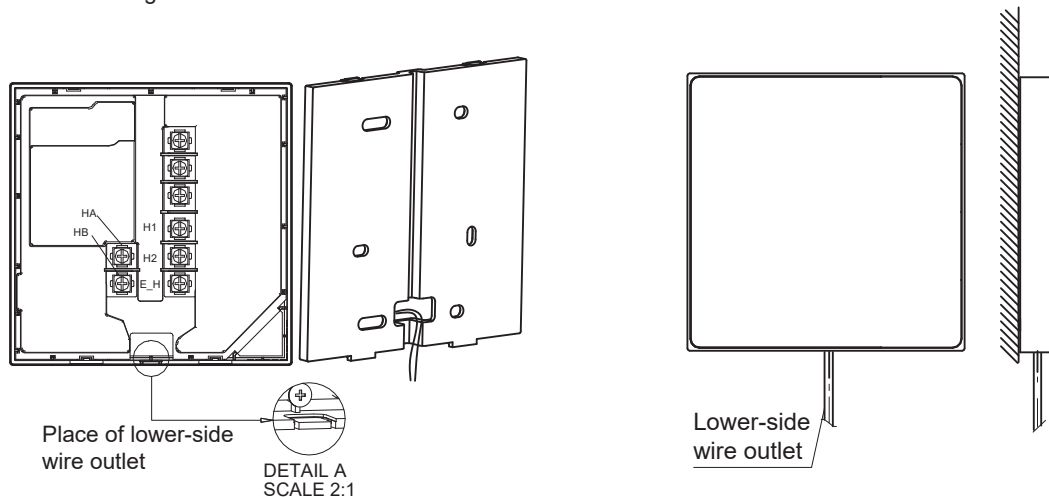

Inside wall wiring (with an 86-type box)

Inside wall wiring (without an 86-type box)

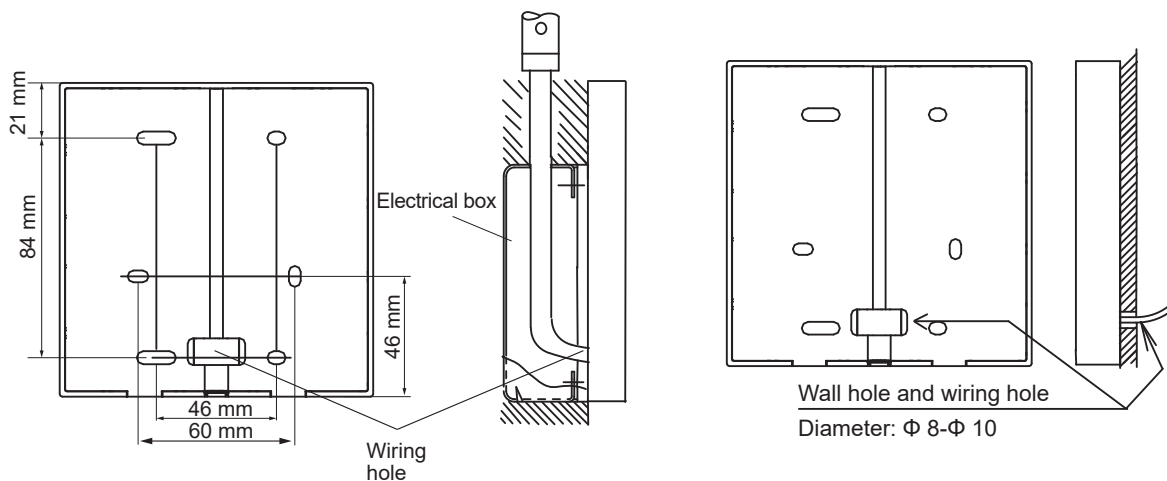

7.4 Mounting

NOTE

Only wall-mount the wired controller, instead of embedded, otherwise maintenance will not be possible.

Mounting on a wall (without an 86-type box)

Directly install the back cover on the wall with four ST 4 x 20 screws.

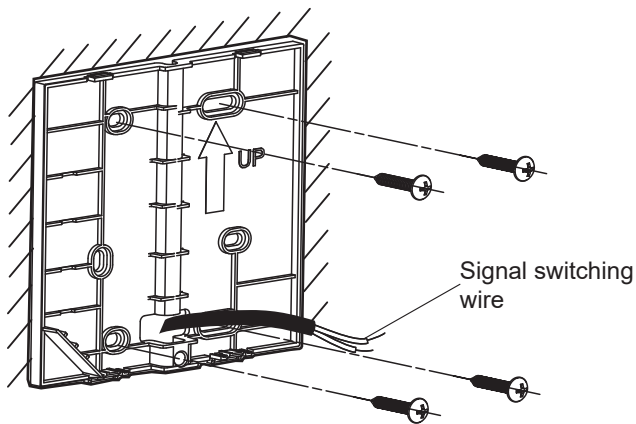

Mounting on a wall (with an 86-type box)

Install the back cover on an 86-type box with two M 4 x 25 screws, and fixing the box on the wall with two ST 4 x 20 screws. If the box is not embedded in the wall completely, you could save two ST 4 x 20 screws depending on the situation.

- Adjust the length of the plastic bolt in the accessory box to make it suitable for installation.
- Fix the wired controller's bottom cover to the wall through the screw bar by using cross head screws. Make sure the bottom cover is set flush on the wall.

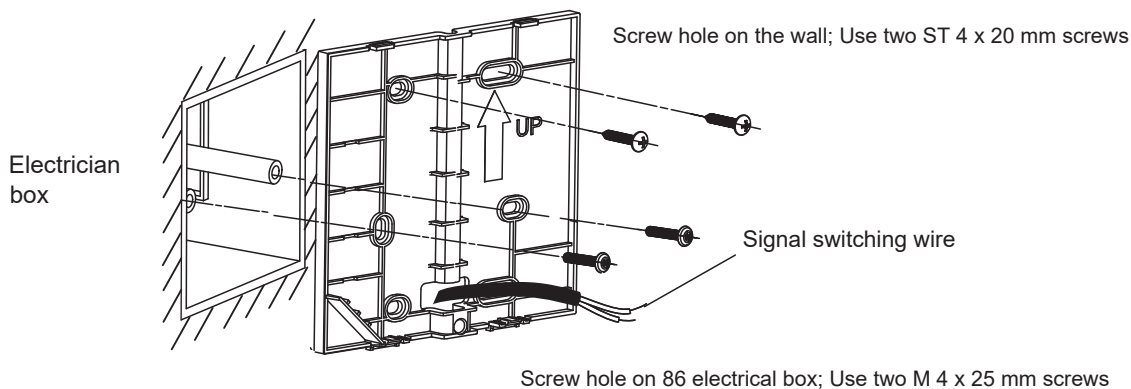

- Buckle the front cover, and fit the front cover to the back cover properly, leaving the wire unclamped during the installation.

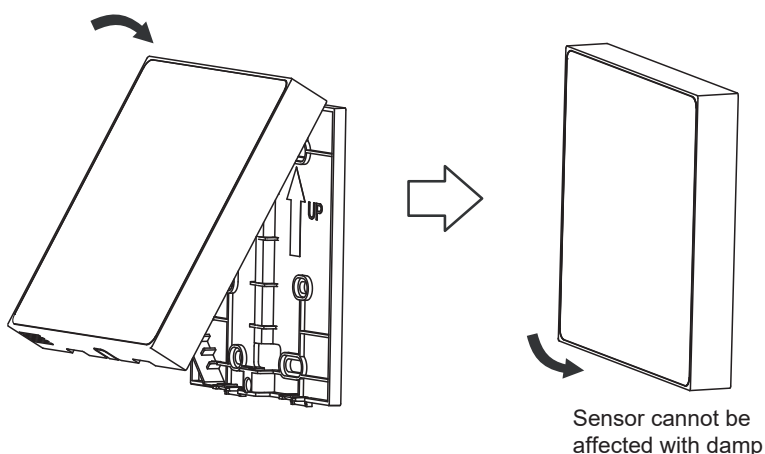

NOTE

To prevent water from entering the remote wired controller, use traps and plugs to seal the wire connections during wiring.

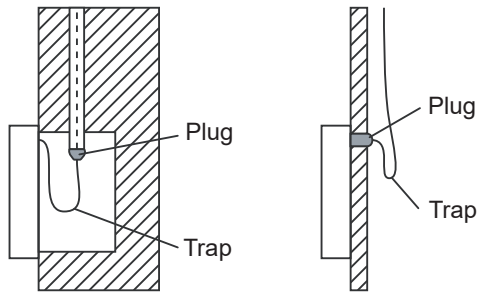

NOTE

Over-tightening the screw can cause deformation of the back cover.

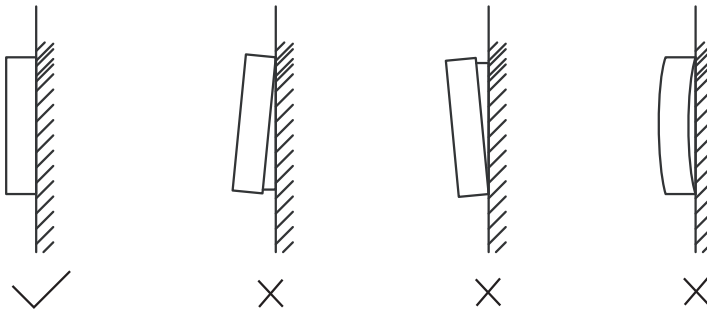

8 COMPLETION OF INSTALLATION

⚠ DANGER

Risk of electrocution.
Risk of burning.

NOTE

The illustrations below are for 8-16 kW units. The principle is the same for 4-6 kW units.

Tightening torque	4.1 N•m
-------------------	---------

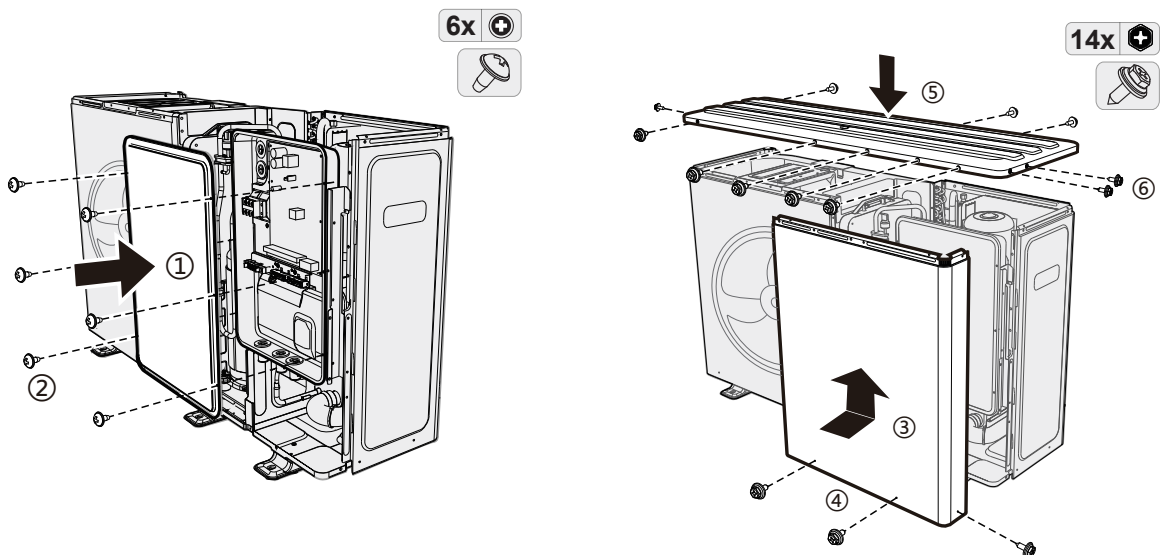

9 CONFIGURATION

The unit should be configured by an authorized installer to match the installation environment (outdoor climate, installed options, etc.) and meet the user demand.

Follow the instructions below for the next step.

9.1 Check before configuration

Before powering on the unit, check the following items:

<input type="checkbox"/>	Field wiring: make sure all wiring connections observe the instructions mentioned in the INSTALLATION, OPERATION AND MAINTENANCE MANUAL.
<input type="checkbox"/>	Fuses, circuit breakers, or protection devices: check the size and type according to the instructions mentioned in the INSTALLATION, OPERATION AND MAINTENANCE MANUAL. Make sure that no fuses or protection devices have been bypassed.
<input type="checkbox"/>	Backup heater's circuit breaker: ensure the backup heater's circuit breaker in the switch box is closed (It varies with the backup heater type). Refer to the wiring diagram.
<input type="checkbox"/>	Booster heater's circuit breaker: ensure the booster heater's circuit breaker is closed (applicable only to units with an optional domestic hot water tank).
<input type="checkbox"/>	Internal wiring: check the wiring and connections inside the switch box for loose or damaged parts, including earth wiring.
<input type="checkbox"/>	Mounting: check and ensure that the unit and the water loop system are properly mounted to avoid water leakage, abnormal noises and vibrations during the unit startup.
<input type="checkbox"/>	Damaged equipment: check the components and piping inside the unit for any damage or deformation.
<input type="checkbox"/>	Refrigerant leak: check the inside of the unit for any refrigerant leakage. In case of refrigerant leakage, follow the relevant content in the "Safety Precautions".
<input type="checkbox"/>	Power supply voltage: check the voltage of the power supply. The voltage must be consistent with the voltage on the identification label of the unit.
<input type="checkbox"/>	Air vent valve: make sure the air vent valve is open (at least 2 turns).
<input type="checkbox"/>	Shut-off valve: make sure that the shut-off valve is fully open.
<input type="checkbox"/>	Sheet metal: make sure all the sheet metal of the unit is mounted properly.
<input type="checkbox"/>	Water volume: make sure the water volume in the system is within the limitation.
<input type="checkbox"/>	Strainer: make sure the strainer is mounted properly and clean.

After powering on the unit, check the following items:

<input type="checkbox"/>	Upon power-on of the unit, nothing is displayed on the wired controller: Check the following abnormalities before diagnosing possible error codes. - Wiring connection issue (power supply or communication signal). - Fuse failure on PCB.
<input type="checkbox"/>	Error code "E8" or "E0" is displayed on the wired controller: - Residual air exists in the system. - The water level in the system is insufficient. Before starting test run, make sure that the water system and the tank are filled with water, and air is removed. Otherwise, the pump or backup heater (optional) may be damaged.
<input type="checkbox"/>	Error code "E2" is displayed on the wired controller: - Check the wiring between the wired controller and the unit.
<input type="checkbox"/>	Initial start-up at low outdoor ambient temperature: To start the initial start-up in low outdoor ambient temperature, the water has to be heated gradually. Please use the preheating for floor function. (Refer to "SPECIAL FUNCTION" in FOR SERVICEMAN mode)

 **NOTE**

For underfloor heating application, floor could be damaged if the temperature rises sharply in a short time.
Please ask the building construction contractor for further information.



More error codes and failure causes can be found in the INSTALLATION, OPERATION AND MAINTENANCE MANUAL.

9.2 Configuration

To initialize the unit, a group of advanced settings should be provided by the installer. The advanced settings are accessible in FOR SERVICEMAN mode.

The overall parameters list of the advanced settings can be found in Annex B. Operation Settings. For more information, refer to the INSTALLATION, OPERATION AND MAINTENANCE MANUAL.

How to enter FOR SERVICEMAN mode

Press and hold  and  simultaneously for 3 seconds to enter the authorization page. Enter password 234 and confirm it. Then, the system jumps into the page with a list of advanced settings.

NOTE

"FOR SERVICEMAN" is only for installer or other specialist with sufficient knowledge and skills.
The end user who use "FOR SERVICEMAN" is regarded as improper use.

Save the settings and quit FOR SERVICEMAN mode

After all settings are adjusted, press , and the confirmation page pops out. Select Yes and confirm to quit FOR SERVICEMAN mode.

NOTE

The settings are saved automatically after you quit FOR SERVICEMAN mode.
Temperature values displayed on the wired controller are measured in °C.

In FOR SERVICEMAN mode, select the target item and enter the setting page. Adjust the enablement settings and values as end user demand. For the list of settings, refer to Annex B. Operation Settings.

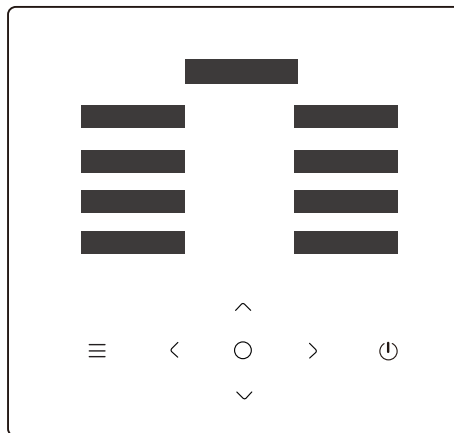

9.3 Modbus mapping table

1) MODBUS PORT COMMUNICATION SPECIFICATIONS

Port: RS-485; H1 and H2 are the Modbus communication ports.

Communication address: Only one-to-one connection is available for the host computer and wired controller, and the wired controller is a slave unit. The communication address of the host computer and wired controller is consistent with the address of HMI Address for BMS (In FOR SERVICEMAN mode).

Baud rate: 9600. Number of digits: 8 Verification: none. Stop bit: 1 bit

Communication protocol: Modbus RTU (Modbus ASCII not supported)

2) Mapping of registers in the wired controller

Please download the file via QR code.



10 COMMISSIONING

Test run is used to confirm the functionality of the valves, air purge, circulation pump operation, cooling, heating and domestic water heating.

Checklist during commissioning

<input type="checkbox"/>	Test run for the actuator
<input type="checkbox"/>	Air purge
<input type="checkbox"/>	Test run for operation
<input type="checkbox"/>	Check of the minimum flow rate

10.1 Test run for the actuator

NOTE

During the commissioning of the actuator, the protection function of the unit is disabled. Excessive use may damage components.

Why

Check whether each actuator is in good working conditions.

What - actuator list

No.	Name		Note
1	SV2	Three-way valve 2	
2	SV3	Three-way valve 3	
3	PUMP_I	Integrated circulation pump	
4	PUMP_O	Additional circulation pump(for Zone 1)	
5	PUMP_C	Zone 2 pump	
6	IBH	Internal backup heater	
7	AHS	Additional heat source	
8	SV1	Three-way valve 1	Invisible if DHW is disabled
9	PUMP_D	DHW pump	Invisible if DHW is disabled
10	PUMP_S	Solar heating loop circulation pump	Invisible if DHW is disabled
11	TBH	Tank booster heater	Invisible if DHW is disabled

How

1	Go to "FOR SERVICEMAN" (Refer to 9.2 Configuration).
2	Find "Test run" and enter the process.
3	Find "Point check" and enter the process.
4	Select the actuator, and press <input type="radio"/> to activate or deactivate the actuator. • The status ON means the actuator is activated, and OFF means the actuator is deactivated.

NOTE

When you return to the upper layer, all actuators turn OFF automatically.

10.2 Air purge

Why

To purge out the remaining air in the water loop.

How

1	Go to "FOR SERVICEMAN" (Refer to 9.2 Configuration).
2	Find "Test run and enter the process.
3	Find "Air purge" and enter the process.
4	Select "Air purge" and press <input type="radio"/> to activate or deactivate the air purge function. • <input checked="" type="radio"/> means the air purge function is activated, and <input type="radio"/> means the air purge function is deactivated.

Besides

"Air vent pump_i output"	To set pump_i output. The higher the value is, the pump gives a higher output.
"Air vent running time"	To set the duration of air purge. When the set time is due, air purge is deactivated.
"Status check"	Additional operation parameters can be found.

10.3 Test run

Why

Check whether the unit is in good working conditions.

What

Circulated pump operation

Cooling operation

Heating operation

DHW operation

How

1	Go to "FOR SERVICEMAN" (Refer to 9.2 Configuration)
2	Find "Test run" and enter the page.
3	Find "Other" and enter the process.
4	Select "XXXX"* and press <input type="radio"/> to run the test. During test, press <input type="radio"/> , select OK and confirm to return to the upper layer. * - Four performance test options are shown in What.

NOTE

In performance test, the target temperature is preset and cannot be changed.

If the outdoor temperature is outside the range of operating temperature, the unit may not operate or may not deliver the required capacity.

In circulated pump operation, If the flow rate is out of recommended flow rate range, please make proper change of the installation, and ensure that the flow rate in the installation is guaranteed in all conditions

10.4 Check of the minimum flow rate

1	Check the hydraulic configuration to find out the space heating loops that can be closed by mechanical, electronic, or other valves.
2	Close all space heating loops that can be closed.
3	Start and operate the circulation pump (See "10.3 Test Run").
4	Read out the flow rate ^(a) and modify the bypass valve settings until the set value reaches the minimum flow rate required + 2 l/min.

(a) During test run for the pump, the unit can operate below the minimum flow rate required.

11 HAND-OVER TO THE USER

- Make sure that the user has the printed documentation and ask the user to keep it for future reference.
- Empty the error history in the HMI before hand-over to the user.
- It is highly recommended to do the WLAN connection of the unit. You can read more information in the APP.
- Explain to the user how to properly operate the system and what to do in case of problems.
- Show the user what to do for the maintenance of the unit. (For the maintenance, refer to the INSTALLATION, OPERATION AND MAINTENANCE MANUAL)
- Explain to the user about energy saving tips. (Refer to the INSTALLATION, OPERATION AND MAINTENANCE MANUAL)

12 MAINTENANCE

Regular checks and inspections at certain intervals are required to guarantee the optimal performance of the unit.

12.1 Safety precautions for maintenance

DANGER

Risk of electrocution.

WARNING

- Please note that some parts of the electric component box are hot.
- Do not rinse the unit. Otherwise, electric shock or fire may occur.
- Do not leave the unit unattended when the service panel is removed.

NOTE

- Before performing any maintenance or service work, touch a metal part of the unit to eliminate static electricity and to protect the PCB.
- Without regular maintenance, the performance of the unit may degrade and the risk of parts damage may increase gradually.

12.2 Maintenance checklist

By user

Items	Recommended frequency
Clean the surrounding of the outdoor unit.	Once a month.

By installer

Items	Recommended frequency
General	
Check if all the parts are in the proper position.	Once a year.
Water loop	
Check if the water pressure is sufficient.	Once a year.
Clean the strainer in water system.	Once a year.
Check if the flow switch works in good condition.	Once a year.
Check if the water pressure relief valve (in water system) works in good condition.	Once a year.
Check if the water pressure relief valve (in DHW water loop) works in good condition.	Once a year.
Check if the insulation of backup heater is in good condition.	Once a year.
Check if there is water leakage in the water loop. Take care if anti-refrigerant is applied.	Once a year.
Check if the booster heater of DHW water tank is clean and in good condition.	Once a year.
Check if the water characteristics fulfills the requirements.	Once a year.
Wiring and electrical parts	
Check if the temperature sensor works in good condition.	Once a year.
Check if the wiring and cables of the installation is in good condition.	Once a year.
Check if the contactors and circuit breakers works in good condition.	Once a year.
Refrigerant loop	
Check if there is refrigerant leakage in the refrigerant loop.	Once a year.

NOTE

Ask the supplier and refer to the SERVICE MANUAL for more information.

13 TECHNICAL DATA

13.1 General

Model	1-phase		1-phase		1-phase			3-phase		
	4 kW	6 kW	8 kW	10 kW	12 kW	14 kW	16 kW	12 kW	14 kW	16 kW
Nominal capacity	Refer to the Technical Data									
Dimensions H×W×D(mm)	717 x 1 299 x 426		865 x 1 385 x 523		865 x 1 385 x 523			865 x 1 385 x 523		
Packing dimensions H×W×D(mm)	885 x 1 375 x 475		1 035 x 1 465 x 560		1 035 x 1 465 x 560			1 035 x 1 465 x 560		
Weight (without backup heater)										
Net weight	90 kg		117 kg		135 kg			137 kg		
Weight (with backup heater)										
Net weight	95 kg		122 kg		140 kg			142 kg		
Connections										
Water inlet/outlet	G1"BSP		G1 1/4"BSP							
Water drain	Hose nipple									
Expansion vessel										
Volume	8 L									
Maximum working pressure (MWP)	8 bar									
Pump										
Type	Water cooled									
No. of speed	Variable speed									
Pressure relief valve in water loop	0.3 MPa(3 bar)									
Operation range - water side										
Heating	Maximum 75 °C									
Cooling	Minimum 25 °C									
Operation range - air side										
Heating	-25 °C to 35 °C									
Cooling	-5 °C to 46 °C									
Domestic hot water by heat pump	-25 °C to 46 °C									

Refrigerant				
Refrigerant type	R290			
Refrigerant charge	0.7 kg	1.1 kg	1.25 kg	1.25 kg

Fuse – on PCB		
PCB name	Main control board	Inverter module
Model name	FUSE-T-10A/250VAC-T-P	FUSE-T-30A/250VAC-T-P-HT
Working voltage (V)	250	
Working current (A)	10	30

Water flow switch		
Model	4/6/8/10 kW	12/14/16 kW
Set point	0.36 m ³ /h ± 0.06	0.6 m ³ /h ± 0.06

13.2 Piping diagram

4-6 kW units (standard)

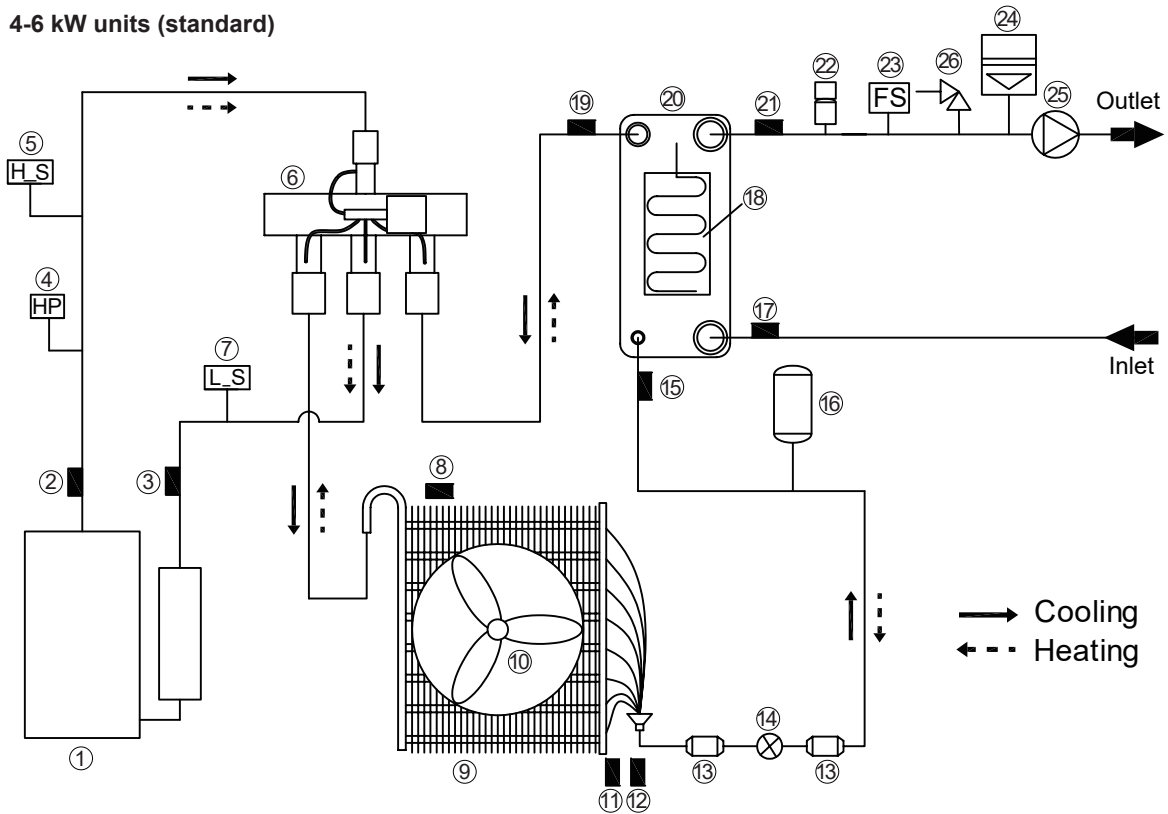

Item	Description	Item	Description
1	Compressor	14	Electronic expansion valve
2	Temperature sensor (compressor discharge)	15	Temperature sensor (plate heat exchanger inlet refrigerant: cooling)
3	Temperature sensor (compressor suction)	16	Liquid reservoir
4	High pressure switch	17	Temperature sensor (water inlet)
5	High pressure sensor	18	Heat tape (plate heat exchanger)
6	4-way valve	19	Temperature sensor (plate heat exchanger outlet refrigerant: cooling)
7	Low pressure sensor	20	Plate heat exchanger
8	Temperature sensor (outdoor air)	21	Temperature sensor (water outlet)
9	Heat exchanger	22	Automatic air vent valve
10	Fan	23	Water flow switch
11	Temperature sensor (heat exchanger)	24	Expansion vessel
12	Temperature sensor (heat exchanger outlet refrigerant: cooling)	25	Water pump
13	Filter	26	Pressure relief valve

8-16 kW units (standard)

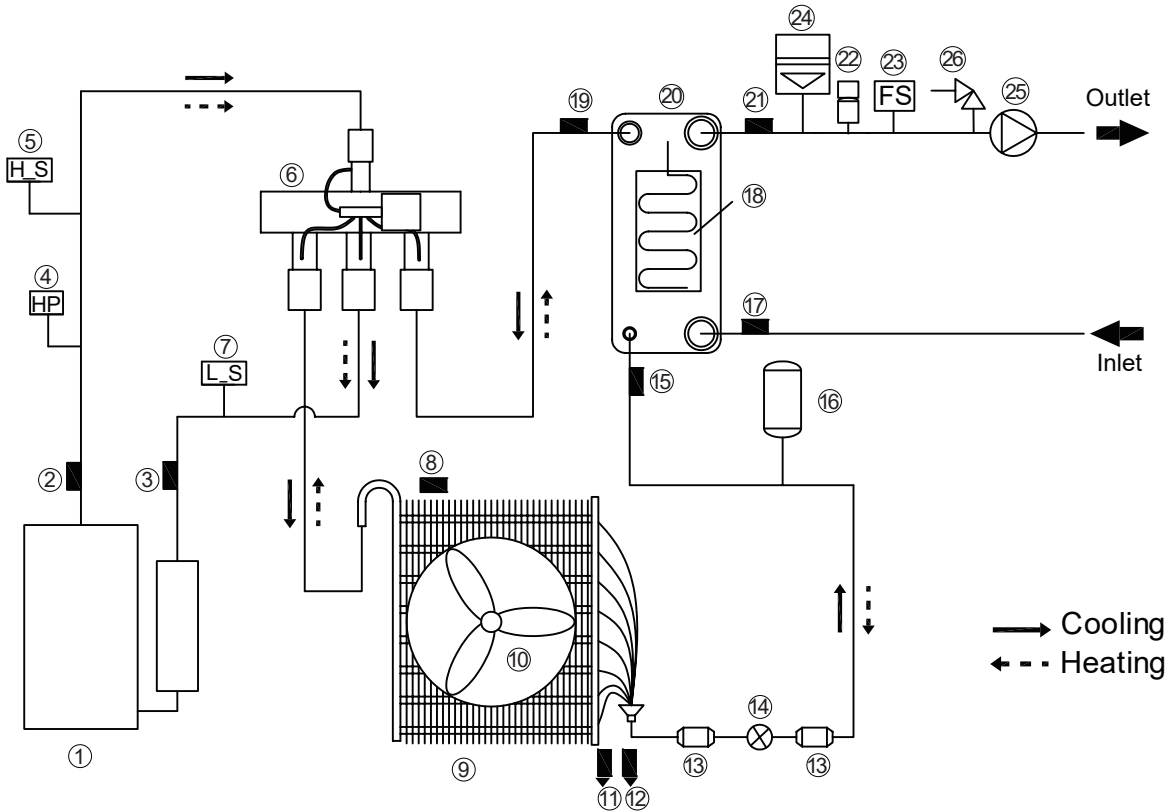

Item	Description	Item	Description
1	Compressor	14	Electronic expansion valve
2	Temperature sensor (compressor discharge)	15	Temperature sensor (plate heat exchanger inlet refrigerant: cooling)
3	Temperature sensor (compressor suction)	16	Liquid reservoir
4	High pressure switch	17	Temperature sensor (water inlet)
5	High pressure sensor	18	Heat tape (plate heat exchanger)
6	4-way valve	19	Temperature sensor (plate heat exchanger outlet refrigerant: cooling)
7	Low pressure sensor	20	Plate heat exchanger
8	Temperature sensor (outdoor air)	21	Temperature sensor (water outlet)
9	Heat exchanger	22	Automatic air vent valve
10	Fan	23	Water flow switch
11	Temperature sensor (heat exchanger)	24	Expansion vessel
12	Temperature sensor (heat exchanger outlet refrigerant: cooling)	25	Water pump
13	Filter	26	Pressure relief valve

4-16 kW (With IBH)

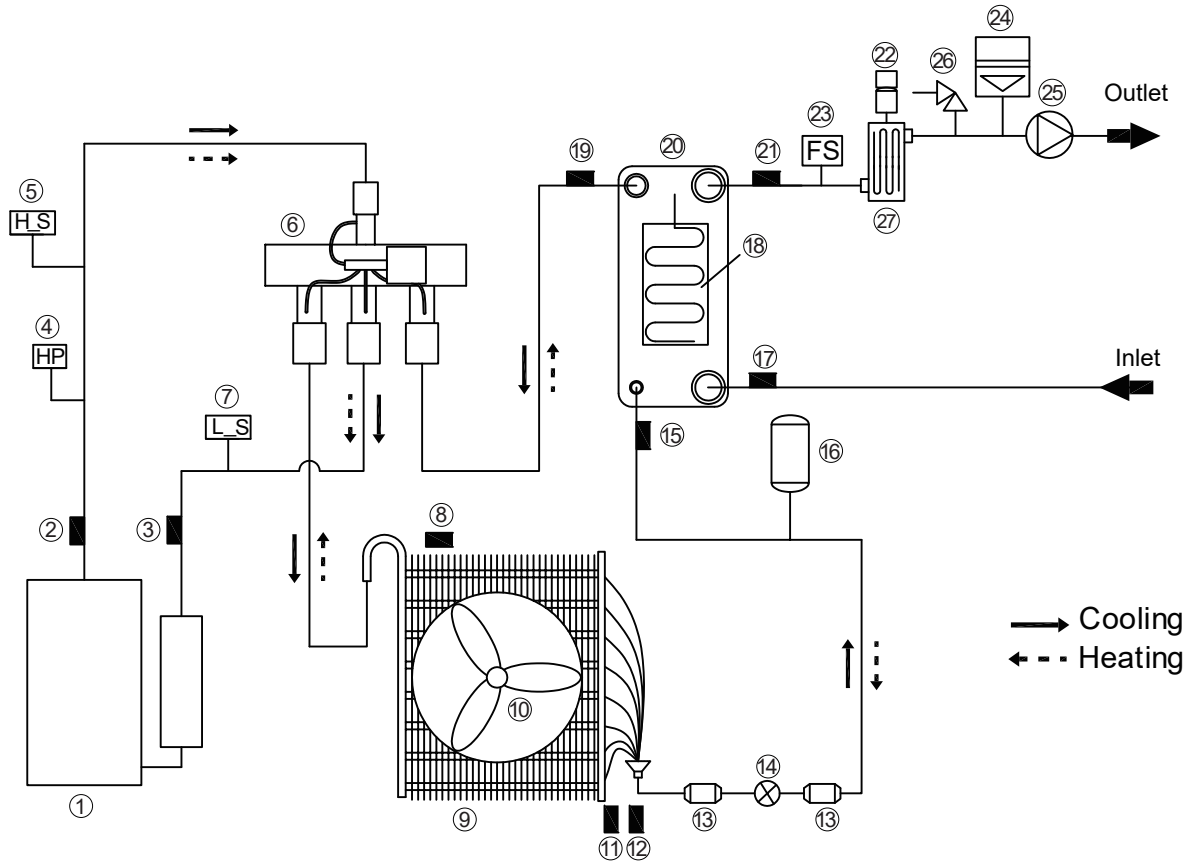

Item	Description	Item	Description
1	Compressor	14	Electronic expansion valve
2	Temperature sensor (compressor discharge)	15	Temperature sensor (plate heat exchanger inlet refrigerant: cooling)
3	Temperature sensor (compressor suction)	16	Liquid reservoir
4	High pressure switch	17	Temperature sensor (water inlet)
5	High pressure sensor	18	Heat tape (plate heat exchanger)
6	4-way valve	19	Temperature sensor (plate heat exchanger outlet refrigerant: cooling)
7	Low pressure sensor	20	Plate heat exchanger
8	Temperature sensor (outdoor air)	21	Temperature sensor (water outlet)
9	Heat exchanger	22	Automatic air vent valve
10	Fan	23	Water flow switch
11	Temperature sensor (heat exchanger)	24	Expansion vessel
12	Temperature sensor (heat exchanger outlet refrigerant: cooling)	25	Water pump
13	Filter	26	Pressure relief valve
		27	Backup heater (optional)

12.3 Wiring Diagram

See the rear side of the electrical box cover for the hard copy.

